

NOTES: UNLESS OTHERWISE SPECIFIED

1. SEE DRAWING NO. CB-00295 AND PROCEDURE P-1000 FOR ASSEMBLY AND TEST INSTRUCTION. PROCEDURES AND ASSEMBLY DRAWINGS ARE FOR INTERNAL USE ONLY.
2. ALL TESTING ARE IAW BATTERY COUNCIL INTERNATIONAL STANDARDS.
3. ALL DIMENSIONS ARE IN INCHES [MM].

REVISIONS			
REV	DESCRIPTION	DATE	APPROVED
A	PRODUCTION RELEASE	5/5/94	DG
B	SEE DCN 0187	4/15/97	DG
C	SEE DCN 0267	2/12/98	JBT
D	ADDED TERMINAL OPTIONS	9/16/99	DG
E	REV. RATING TABLE, DEL. GPL-8DS, ADDED NOTES	3/23/00	DG
F	REDESIGNED CONTAINER, COVER	4/2/02	JBT
G	ADDED AUTO POST OPTION, 1.13 WAS 1.05	4/3/04	JBT

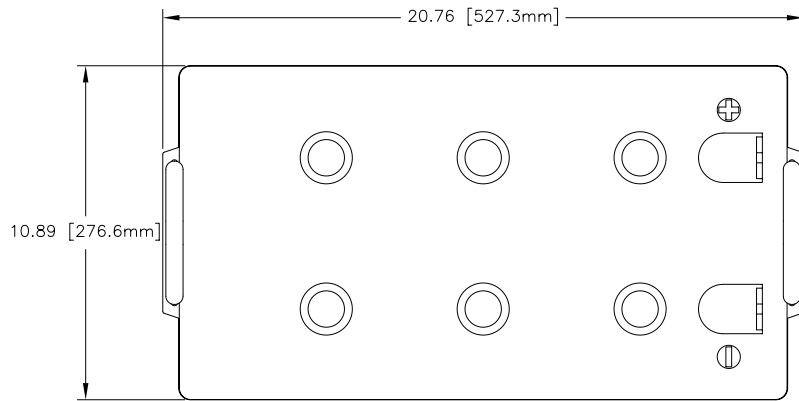

GPL-8D TERMINAL OPTIONS

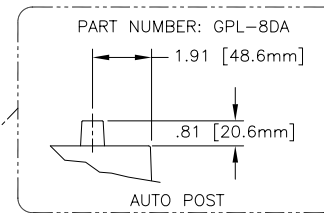
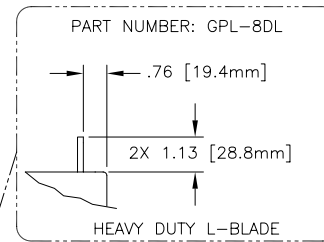

NOTE: SEE OPTIONS LISTED

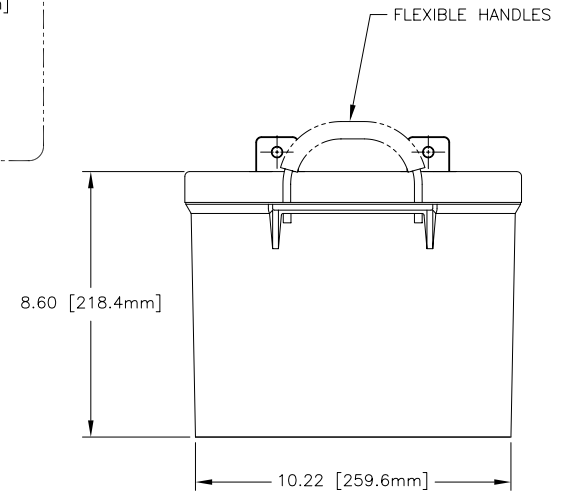
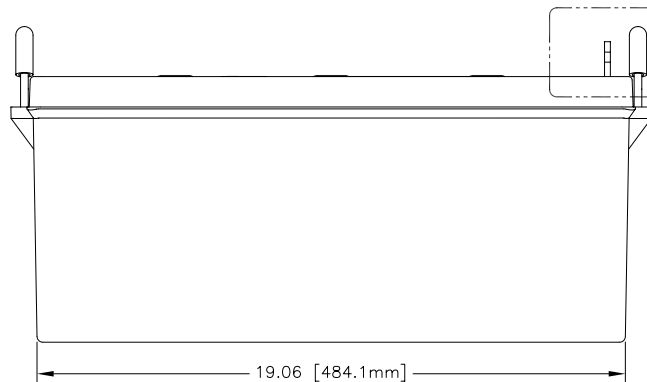

CAPACITY RATINGS	
PART NUMBER	GPL-8D
NOMINAL WEIGHT	162 LBS[73.6 KG]
AMPERE HOUR CAPACITY @ 20 HOUR 1.75 VOLTS/CELL @ 77°F (25° C)	255 AH
MINUTES OF DISCHARGE @ 25 AMPS 1.75 VOLTS/CELL @ 77°F (25° C)	475 MIN

ENVELOPE DRAWING

QTY REQD	CAGE CODE	PART OR IDENTIFYING NO.	NOMENCLATURE OR DESCRIPTION	MATERIAL SPECIFICATION	ITEM NO.
PARTS LIST					
UNLESS OTHERWISE SPECIFIED DIMENSIONS ARE IN INCHES TOLERANCES ARE:			CONCORDE BATTERY CORPORATION 2009 SAN BERNARDINO RD, W. COVINA, CA 91790		
FRACTIONS ±1/32	DECIMALS .XX ± .06	ANGLES ±1°	TITLE BATTERY, 12 VOLT, GPL-8D		
CONTRACT NO. N/A			APPROVALS	DATE	
			DRAWN TORRES J.	5/9/94	
TREATMENT			CHECKED JR	5/9/94	
FINISH			APPROVED DG	5/9/94	
SIMILAR TO N/A	ACT WT N/A	OLD WT N/A	ISSUED AT	6/7/04	
			SIZE C	CAGE CODE 63017	DWG NO. GPL-8D
			SCALE NONE		REV G
			SHEET 1 OF 1		