



DM-40 **Operator's Manual**

Automotive Multimeter and Inductive Amp Probe

The DM-40 is the auto industry's answer to pocket portability in a professionally accurate meter.

TABLE OF CONTENTS

Battery Replacement	2
Safety	3
Maintenance and Cleaning	3
Features	4
Controls and Functions	4 - 5
Operation Instructions	
DC/AC Current Measurements	6
DC/AC Voltage Measurements	7
Frequency (Hz) Measurement	8
Continuity Test	8
Resistance Measurement	8
Relative "ZERO" Measurements	9
Holding the LCD Reading	9
Finding the MAX/MIN Value	9
Charging System Tests	
State of Charge	10
Amp Draw Check	10
Alternator Test	11
Starter Draw Test	12
Specifications	13 - 14
Warranty	15
Contact Information	16

BATTERY REPLACEMENT

When the low battery symbol is displayed on the LCD or the LCD is dark, replace the old batteries with two (AA) batteries.

1. Turn the power off and remove the test leads from the clamp meter.
2. Remove the screw of the battery cover.
3. Lift and remove the battery cover.
4. Remove the old batteries.
5. Insert two (AA) batteries.
6. Replace the battery cover and secure the screw.

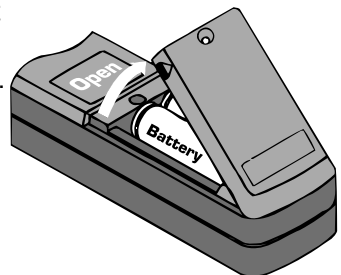

SAFETY

- Carefully read all operating instructions before using the DM-40
- Wear eye protection when working around batteries.
- Keep sparks, flames, or cigarettes away from batteries.
- Keep hair, hands, and clothing as well as tester leads and cords away from moving blades and belts.
- Provide adequate ventilation to remove car exhaust.
- **WARNING:** If the clamp meter is used in a manner not specified by the manufacturer, the protection provided by the clamp meter may be impaired.



Overvoltage Category I (CAT I):

Equipment for connection to circuits in which measures are taken to limit the transient overvoltages to an appropriate low level.

Overvoltage Category II (CAT II):

Energy-consuming equipment to be supplied from the fixed installation.

Overvoltage Category III (CAT III):

Equipment in fixed installations.

Definition of Symbols on the DM-40 and in the manual.



Caution: Refer to Accompanying Documents



Caution: Risk of Electric Shock



Double Insulation

MAINTENANCE and CLEANING

- Periodically wipe the case with a damp cloth and detergent; do not use abrasives or solvents.
- Use the hand strap to avoid accidental dropping. Negligent use of your meter will void the warranty.
- Keep away from heat and liquid solvents.
- Keep in a protective place when not in use.

FEATURES

- Accurate AC/DC digital clamp meter for current measurement.
- High resolution readout (10mA to 40A DC/AC range).
- One touch zero for DC Amps adjustment.
- 23 mm diameter jaw. Ideal for working under dash or in cable bundles.
- Fast bar graph display (20 times/sec.) for transient observation.
- Continuity and frequency measurements.
- Max/Min and Data Hold functions.
- 600V overload protection for ohm measurement.
- ON/Off switch to conserve battery life.

CONTROLS AND FUNCTIONS

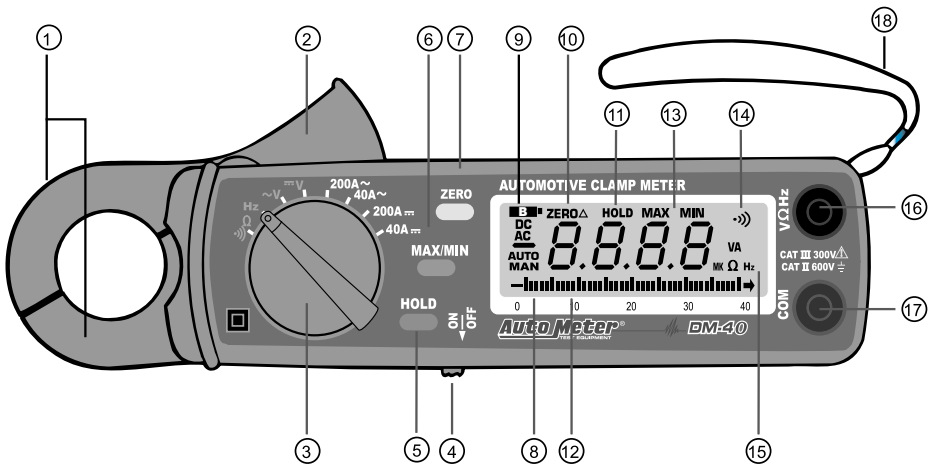

1. **Transformer Jaw** is used to pick up DC/AC current signal. The jaw must enclose a single conducting wire.
2. **Transformer Trigger** is used to open the jaw.
3. **Function Selector Switch** is used to select the function such as DCA, ACA, DCV, ACV, Hz, Ohm and Continuity.
4. **On/Off Switch** is used to turn the power on or off.
5. **Data Hold Button** holds the LCD reading when pushed. Press again to release it.

CONTROLS AND FUNCTIONS CONT.

6. **Max/Min Hold Button** is used to enable the maximum or minimum value to be displayed and updated during measurement. Press once, minimum value will be displayed and updated. Press again, maximum value will be displayed and updated. Press the third time and the meter will return to normal measurement mode. The Zero function will be disabled if MAX/MIN is enabled.
7. **Zero/Relative Button** sets the current reading to zero and is used as a zero reference value for all subsequent measurements. This function is also used to remove offset values caused by the residual magnetism remaining in the core after a DC current measurement. The Zero/Relative function will be disabled if the MAX/MIN button is pressed.
8. **LCD** is a 3 3/4 digit Liquid Crystal Display with a maximum indication of 3999. The functions included are units, symbols, bar graph, sign, decimal points, low battery symbols, MAX/MIN symbols, and zero symbol.
9. **Battery Symbol** appears if the battery voltage drops below the minimum required voltage. Refer to page 3 for battery replacement.
10. **Zero/Relative Symbol** means a reference value has been subtracted from the actual reading. The reading shown is an offset value. Press and hold the zero button for 2 seconds to disable this function.
11. **Data Hold Symbol** appears on the LCD when the hold button is pressed.
12. **Bar graph** has forty segments. It displays segments proportional to the actual reading. Each segment represents one count.
13. **MAX** or **MIN** is displayed on the LCD when the MAX/MIN button is pressed.
14. **Continuity Symbol** appears on the LCD if the ohm and continuity function is selected.
15. **Units** are displayed on the LCD when a function is selected. The corresponding symbols are: V, A, W, and Hz.
16. **VWHz Input Terminal (Red)** is used as input for voltage, ohm/continuity or frequency measurements.
17. **COM Terminal (Black)** is used as a common reference input.
18. **Hand Strap** allows you to put your hand through to avoid accidental drop of the clamp meter.

DC/AC CURRENT MEASUREMENTS

WARNING: Make sure that all the test leads are disconnected from the meter's terminals for current measurement.

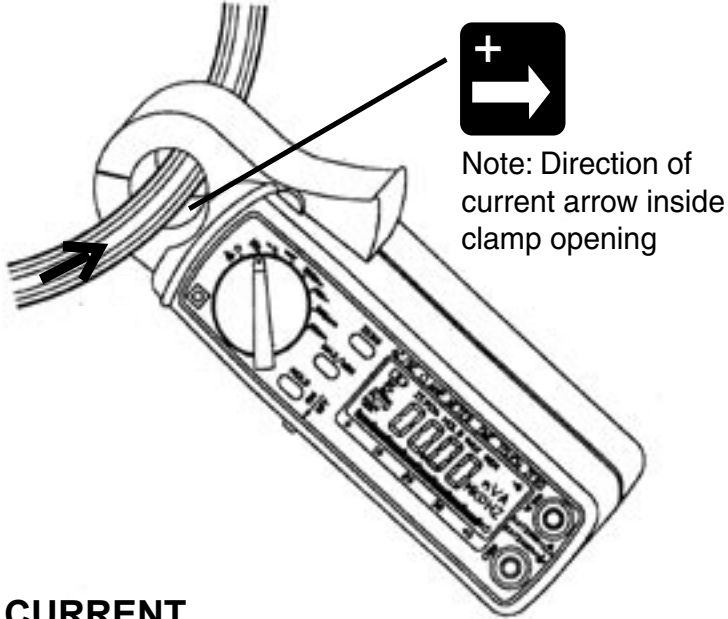

DC CURRENT

1. Set the rotary switch at 40A \equiv or 200A \equiv
2. Push the zero button to zero Amp reading.
3. Press the trigger to open the jaw and fully enclose the conducting wire to be measured. Be sure there is no air gap between the two half jaws.
4. Read the measured value from the LCD.

AC CURRENT

1. Set the rotary switch at 40A \sim or 200A \sim .
2. Press the trigger to open the jaw and fully enclose the conducting wire to be measured. Be sure there is no air gap between the two half jaws.
3. Read the measured value from the LCD.

DC/AC VOLTAGE MEASUREMENTS

WARNING: Maximum input for DC Volts is 1000, and for AC Volts is 750. Do not attempt to take any voltage measurement that exceeds the limits. Exceeding the limits could cause electrical shock and damage to the meter.

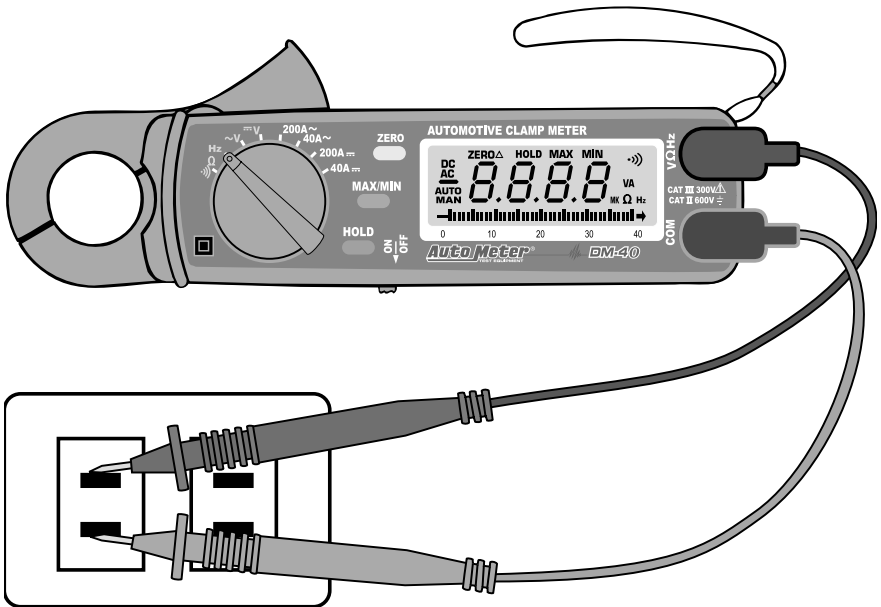

DC VOLTAGE

1. Set the rotary switch at $\text{---}V$.
2. Insert the test leads into the input jack.
3. Connect the test prods of the test leads in PARALLEL to the circuit to be measured.
4. Read the measured value from the LCD display.

AC VOLTAGE

1. Set the rotary switch at $\sim V$.
2. Insert the test leads into the input jack.
3. Connect the test prods of the test leads in PARALLEL to the circuit to be measured.
4. Read the measured value from the LCD display.

FREQUENCY AND CONTINUITY TESTS

FREQUENCY (Hz) MEASUREMENT

1. Set the rotary switch to Hz.
2. Insert the test leads into the input jacks.
3. Connect the test probes in PARALLEL to the signal or circuit to be measured.
4. Read the measured value on the LCD.

RESISTANCE MEASUREMENT

WARNING: Before taking any in-circuit resistance measurement, remove power from the circuit being tested and discharge all the capacitors.

1. Set the rotary switch to Ω .
2. Insert the test leads into the input jack.
3. Connect the test probes of the test leads to the two ends of the resistor or circuit to be measured.
4. Read the measured value from the LCD.

CONTINUITY TEST

1. Turn the rotary switch to Ω position.
2. Insert the test leads into the input jack.
3. Connect the test probes of the test leads to the two ends of the resistor or circuit to be measured.
4. Read the measured value from the LCD.
5. If the resistance is lower than 40Ω , a beeping sound will be heard.

RELATIVE READING MEASUREMENTS

ZERO

The “ZERO” button also can be used to make a relative measurement. Once the button is pushed, the current reading is set to zero and a zero symbol will be displayed on LCD. All the subsequent measurement shall be displayed as a relative value with respect to the value being zeroed. This function can be used to remove offset values caused by the residual magnetism remaining in the core from DC current measurements. Press the zero button for 2 seconds to return to normal mode. This function is disabled if MAX/MIN function is enabled. Please watch for symbol displayed on LCD.

HOLDING THE LCD READING

Press the HOLD button and the reading will be held on the LCD. Press again to release.

FINDING THE MAX/MIN VALUE

Press the MAX/MIN button to enable the maximum and minimum values to be recorded and updated during measurement. Push the button once, the maximum value will be displayed and updated. Push again (second push), the minimum value will be displayed. Push again (third push), the MAX/MIN function will be disabled by returning to normal measurement mode. If MAX/MIN button is pressed, the ZERO function will be disabled and the ZERO symbol will disappear from LCD.

CHARGING SYSTEM TESTS



The following section shows what you can do with the DM-40 in testing your charging system

State of Charge

1. Select DC Volts on the DM-40.
2. Place the Volt leads to the red (+) positive and black (-) battery terminals.
3. If the Volts are less than 12.5 Volts the battery needs charging.

Amp Draw Check

4. Turn off ignition and all accessories.
5. Select DC 40 Amps on the DM-40.
6. Zero the DM-40 by pressing the yellow button.
7. Clamp the DM-40 around the positive (+) battery cable . Make sure it is clamped around all wires.
8. If the display is above 2 Amps there is probably a draw upon the battery by the electrical system. This will drain the battery. Isolate and follow a suspected circuit and repeat reading until the problem is found. Consider a negligible drain with an on board computer.

ALTERNATOR TEST

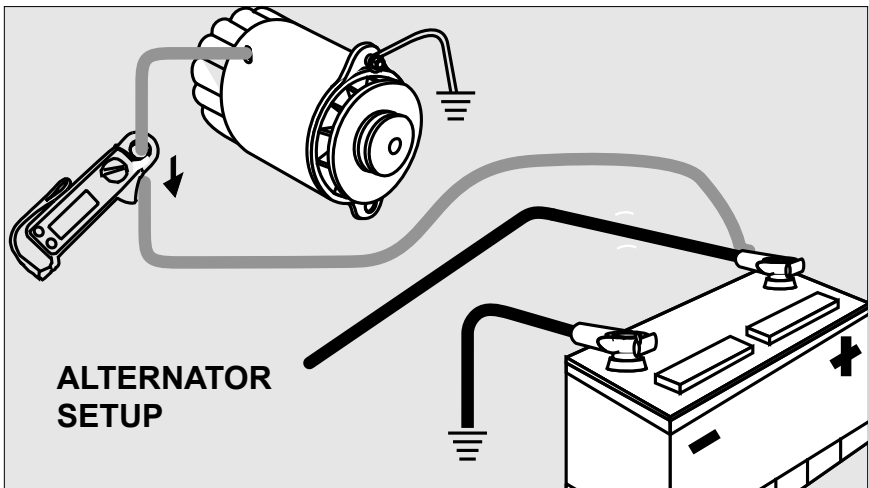

1. Select DC Volts on the DM-40.
2. Start the engine.
3. Place the Volt leads to the red (+) positive and black (-) battery terminals.
4. Allow voltage to stabilize. The reading should be from 13.2 to 15.0 Volts DC. If the reading is high the alternator is over charging and could damage the battery.
5. Turn on all accessories including the headlights.
6. The reading should be from 12.8 to 15.0 Volts DC. If the reading is low the alternator is not charging.
7. Switch the DM-40 to DC 200 Amps.
8. Clamp the DM-40 around the positive alternator conductor leading to the positive terminal of the battery (See illustration to the right).
9. Make sure the small arrow inside the clamp is pointing in the direction of the current towards the battery. Also make sure the DM-40 is clear of any moving belts, fan blades or anything that might damage the meter.
10. If output is lower in DC Amps than the accessories would draw then the alternator may not be charging. Repeat step 6 to see if the voltage has dropped.
11. Select the AC 40 Amp on the DM-40.
12. Clamp the DM-40 as explained in step 11.
13. With the engine still running and all accessories on, the current ripple should be less than 10 Amps AC. If more, the diodes are bad.

STARTER DRAW TEST

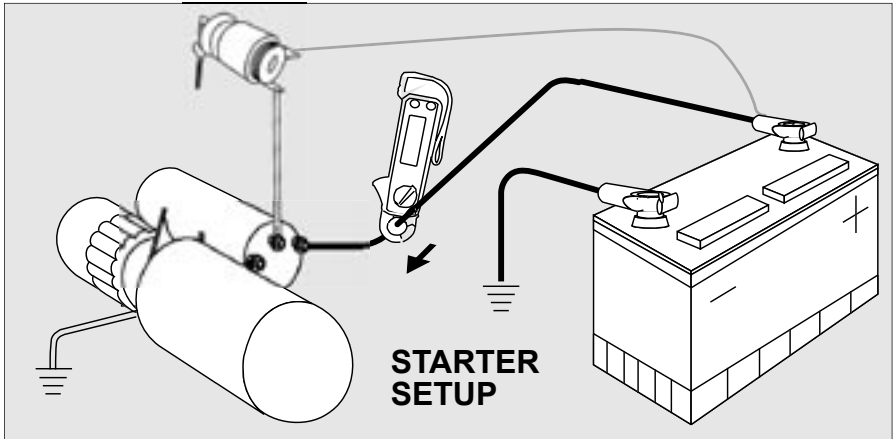

1. Check with manufacture's proper procedure to disable ignition if needed. Improper methods could cause damage to vehicles that are computer controlled.
2. Determine the manufactures Starter Draw specifications. If not available use the following chart as a guide.

4 Cyl Gas 120-250A	6 Cyl Gas Up to 250A	8 Cyl Gas Up to 250A
4 Cyl Dsl Up to 350A	6 Cyl Dsl Up to 450A	8 Cyl Dsl Up to 650A

3. Select DC 200 Amp and zero the DM-40 by pressing the yellow button.
4. Press the MAX/MIN button twice and make sure the display reads HOLD MAX.
5. Clamp the DM-40 around the positive conductor leading to the starter (See illustration above). Make sure the small arrow inside the clamp is pointing in the direction of the current towards the starter. Also make sure the DM-40 is clear of any moving belts, fan blades or anything that might damage the meter.
6. Start or crank the engine for 3 to 5 seconds.
7. Read the DM-40 and compare with manufactures specifications.
8. High Amp reading indicates a faulty starter or engine timing that would put an extra load upon the starter. Possible starter problems are shorted windings, bent armature, broken housing or bad bearings.

SPECIFICATIONS (23°C±5°C)

DC Current:

Range	Resolution	Accuracy	Overload Protection
40A	10mA	±1.0%±2dgts	DC 400A
0-150A	100mA	±1.0%±2dgts	DC 400A
150-200A	100mA	±2.2%±2dgts	DC 400A

AC Current:

Range	Resolution	Accuracy		Overload Protection
		50/60 Hz	40-1KHz	
40A	10mA	±1.0%±3dgts	±1.5%±4dgts	AC 400A
0-150A	100mA	±1.0%±3dgts	±1.5%±4dgts	AC 400A
150-200A	100mA	±2.2%±3dgts	±2.5%±4dgts	AC 400A

DC Voltage: (Input Impedance: 10MΩ)

Range	Resolution	Accuracy	Overload Protection
400V	0.1V	±1.0%±2dgts	DC 1000V

AC Voltage: (Input Impedance 10MΩ)

Range	Resolution	Accuracy		Overload Protection
		50/60 Hz	40-1KHz	
400V	0.1V	±1.5%±2dgts	±2.0%±5dgts	AC 800V

RESISTANCE (Ω): (open voltage 0.4)

Range	Resolution	Accuracy	Overload Protection
40-400Ω	0.1Ω	±1.0%±2dgts	AC 600V

CONTINUITY: (open voltage 0.4v, Overload Protection AC 600V)

Range	Resolution	Accuracy	Beeping
40-400Ω	0.1Ω	±1.0%±2dgts	<40.0Ω (approx.)

FREQUENCY: (Auto Range)

Range	Resolution	Accuracy	Sensitivity	OL Protection
100-1000K	0.01-100	±1.0%±2dgts	2V	AC 600V

SPECIFICATIONS CONTINUED

Indoor Use

Conductor Size:	23mm max. (approx.)
Battery Type:	Two 1.5V AA
Display:	3 3/4 LCD with 40 seg. bar graph
Overload Indication:	Left most digit blanks
Power Consumption:	10mA (approx.)
Low battery Indication	3
Sampling Time:	2 times/sec. (display) 20 times/sec. (bar graph)
Operating Temperature:	-10° C to 50° C
Operating Humidity:	Less than 85% relative
Storage Temperature	-20° C to 60° C
Storage Humidity	Less than 75% relative
Dimension:	7.2" x 2.5" x 1.4"
Weight:	190g (batteries included)
Accessories:	Carrying bag Users manual 2-1.5V AA batteries

LIMITED WARRANTY

SERVICE

For service send your product to Auto Meter in a well-packed shipping carton. Please include a note explaining what the problem is along with your phone number. If you are sending the product back for Warranty adjustment, you must include a copy (or original) of your sales receipt from the place of purchase.

12 MONTHS FROM DATE OF PURCHASE-CABLES 90 DAYS

The manufacturer warrants to the consumer that this product will be free from defects in material or workmanship for a period of twelve (12) months from the date of original purchase.

Products that fail within this 12 month warranty period will be repaired or replaced at the manufacturer's option to the consumer, when determined by the manufacturer that the product failed due to defects in material or workmanship. This warranty is limited to the repair or replacement of parts and the necessary labor by the manufacturer to effect the repair or replacement of the product. In no event shall the manufacturer be responsible for special, incidental or consequential damages or costs incurred due to the failure of this product.

Improper use, accident, water damage, abuse, unauthorized repairs or alterations voids this warranty. The manufacturer disclaims any liability or consequential damages due to breach of any written or implied warranty on its test equipment.

WARRANTY AND SERVICE INFORMATION

Warranty claims to the manufacturer's service department must be transportation prepaid and accompanied with dated proof of purchase. This warranty applies only to the original purchaser and is non-transferable. Shipper damage incurred during return shipments is not covered under this warranty. It is the responsibility of the shipper (the customer returning the Test Equipment) to package the tester properly to prevent any damage during return shipment. Repair costs for such damages will be charged back to shipper (customer returning the Test Equipment). Protect the product By shipping in original carton or add plenty of over-pack cushioning such as crumpled up newspaper.



How to use this manual if viewed in full screen format.

- ***Click on this page or any page being viewed and you will return to the Table of Contents hyperlinks.***
- ***You can also use your left arrow to navigate back and your right arrow to navigate forward.***
- ***Press Ctrl P to print. Be sure to select desired pages or print all.***
- ***To return to this page navigate to last page.***
- ***Press ESC to Exit full view.***



Auto Meter Products Inc.

350 West Center Street
Pleasant Grove, Utah 84062

Service (801) 785-0051 ext. 223
Toll Free (866) 883-TEST (8378)
Fax (801)785-8699
www.autometertest.com