



# POWERSPORT BATTERY Maintenance-Free AGM Battery Series

## CT9B-BS 12V 8AH(10HR)



**JIS JIS**  
D5302 C8702

### Specification

BATTERY TYPE NUMBER	VOLTAGE (V)	CAPACITY AH (10HR)	MAXIMUM DIMENSIONS						WEIGHT			
			MILLIMETERS (±2 mm)			INCHES (±1/16 in)			BATTERY ONLY		INCLUDE ACID AND PACKAGE	
			L	W	H	L	W	H	Kg	Lbs	Kg	Lbs
CT9B-BS	12	8	151	69	105	5 15/16	2 11/16	4 1/8	2.30	5.07	3.19	7.02

### Dimension

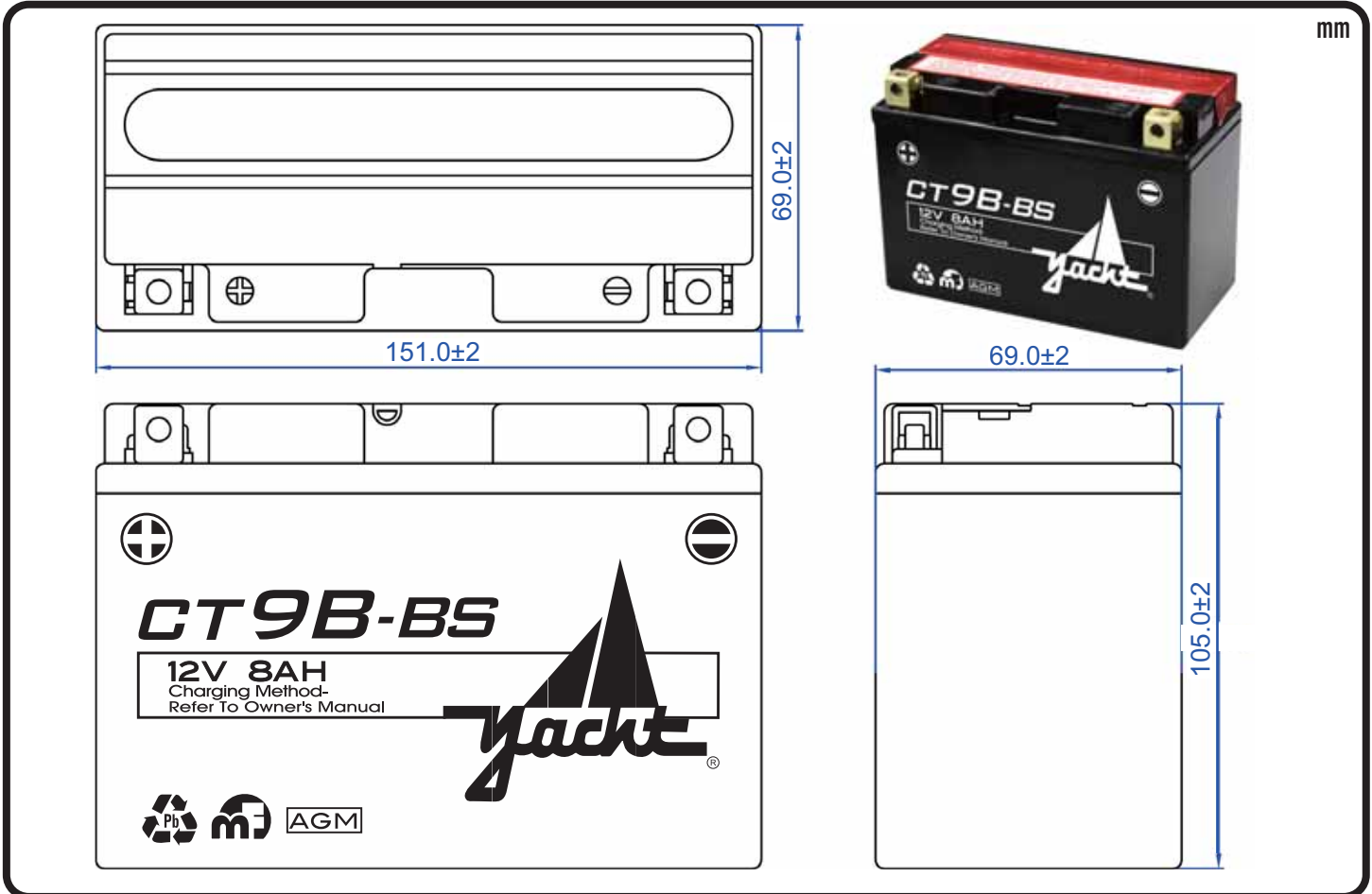

### Terminal Configuration

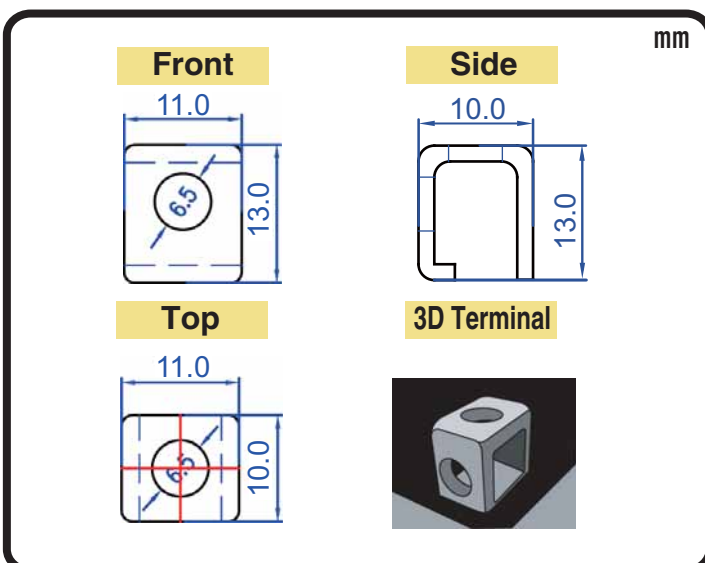

### Nut & Bolt Hardware Kits

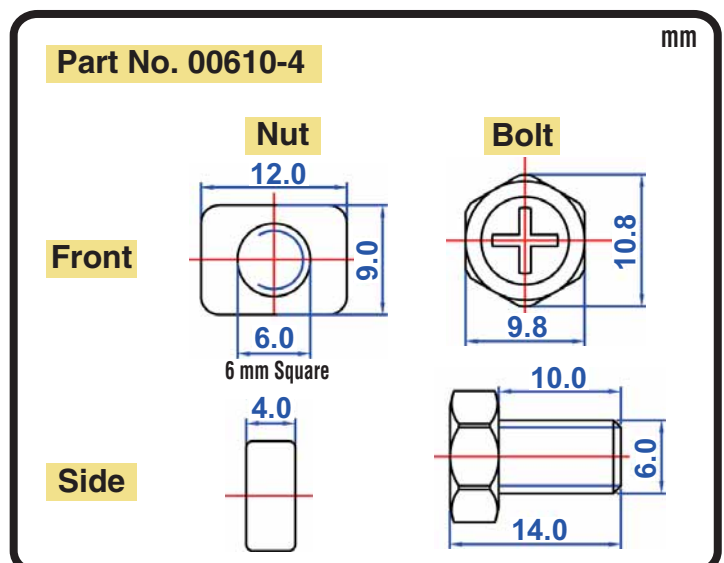

**International Sales Division**  
4F-5, No. 123, Sec. 3, Taichung Port Road,  
Taichung, 40767 Taiwan, R.O.C.  
Tel : 886-4-2358-0578  
Fax : 886-4-2358-0059  
E-mail : sales@yacht-battery.com

**Alpharetta Office**  
#429, 12460 Crabapple Road, Suite 202,  
Alpharetta, GA 30004, U.S.A.  
Tel : 1-678-580-0504  
Fax : 1-888-456-5695  
E-mail : Chuck.Fowler@yacht-battery.com

**Pennsylvania Office**  
93 S. Sunrise Lane, Boyertown,  
PA 19512, U.S.A.  
Tel : 1-610-689-0443  
Fax : 1-888-373-6466  
E-mail : Dave.Beidler@yacht-battery.com