

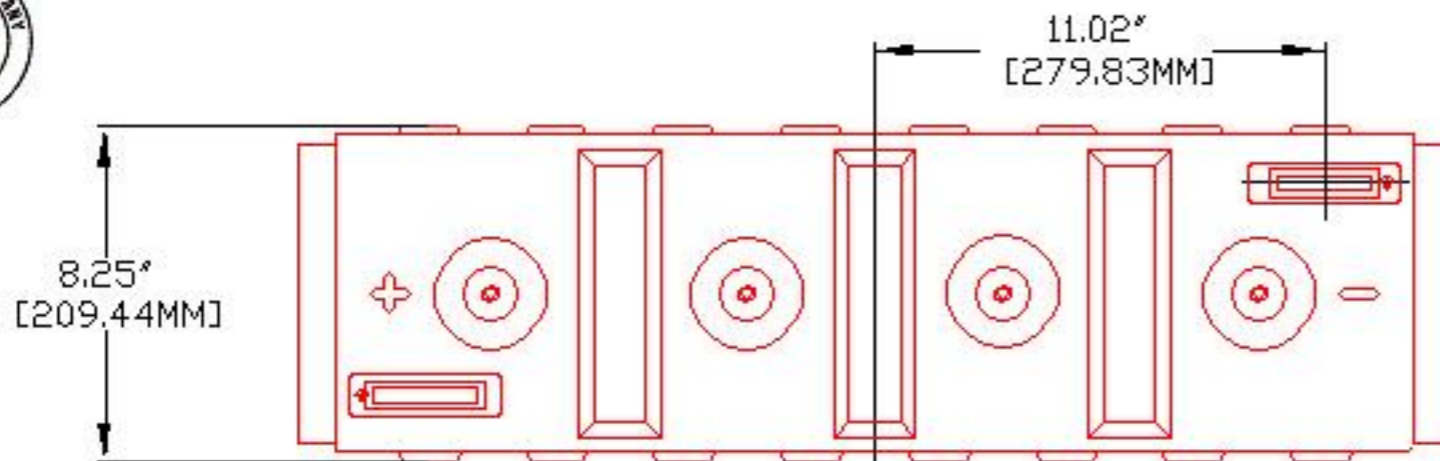

# DEEP CYCLE-MARINE SERIES 5000

<b>BATTERY TYPI</b>	<b>VOLTS</b>	<b>8</b>	<b>8 NS 23PM</b>
<b>DIMENSIONS</b>			
LENGTH			718 MM 28 1/4 INCHES
WIDTH			210 MM 8 1/4 INCHES
HEIGHT			464 MM 18 1/4 INCHES
<b>WEIGHT DRY</b>			80 KG 176 LBS.
<b>WEIGHT WET</b>			110 KG 242 LBS.
<b>CONTAINER CONSTRUCTION</b>			
INNER CONTAINER			POLYPROPYLENE
INNER COVER			POLYPROPYLENE - HEAT SEALED TO INNER CONTAINER
OUTER CONTAINER			HIGH DENSITY POLYETHYLENE
OUTER COVER			HIGH DENSITY POLYETHYLENE SNAP FIT TO OUTER CONTAINER
HANDLES			MOLDED
<b>PLATES PER CELL</b>			23
<b>ELECTROLYTE RESERVE</b>	<b>ABOVE PLATES</b>		143 MM 5.63 INCHES
<b>DESIGN CRITREA</b>	10 YEAR WARRANTY	1350 CYCLES	15 YEAR LIFE
<b>POSITIVE PLATE DIMENSION</b>			
HEIGHT			222 MM 8.750 INCHES
WIDTH			143 MM 5.625 INCHES
THICKNESS			3.81 MM 0.150 INCHES
<b>NEGATIVE PLATE DIMENSION</b>			
HEIGHT			222 MM 8.750 INCHES
WIDTH			143 MM 5.625 INCHES
THICKNESS			3.05 MM 0.120 INCHES
<b>SEPARATOR INSULATION</b>	SEPARATOR THICKNESS		0.105 INCH
	0.020" GLASS MAT		
<b>TERMINALS</b>	FLAG WITH STAINLESS STEEL NUTS AND BOLTS		
<b>COLD CRANK</b>	CCA	0°F / -17.8°C	1520
	MCA	32°F / 0°C	1900
	<b>RESERV</b>		716
	<b>MINUTES AT 25A</b>		
<b>CAPACITY</b>	20 HR RATE		430
			CAP / AH CURRENT / AMPS
<b>CAPACITY AT THE 20 HOUR RATE</b>	<b>1.265 SP. GR.</b>	<b>430</b>	<b>21.5</b>
CAPACITY AT THE 15 HOUR RATE	1.265 SP. GR.	404	26.9
CAPACITY AT THE 12 HOUR RATE	1.265 SP. GR.	383	31.9
CAPACITY AT THE 10 HOUR RATE	1.265 SP. GR.	366	36.6
CAPACITY AT THE 8 HOUR RATE	1.265 SP. GR.	344	43.0
CAPACITY AT THE 6 HOUR RATE	1.265 SP. GR.	318	53.0
CAPACITY AT THE 5 HOUR RATE	1.265 SP. GR.	301	60
CAPACITY AT THE 4 HOUR RATE	1.265 SP. GR.	280	70
CAPACITY AT THE 3 HOUR RATE	1.265 SP. GR.	254	85
CAPACITY AT THE 2 HOUR RATE	1.265 SP. GR.	219	110
CAPACITY AT THE 1 HOUR RATE	1.265 SP. GR.	155	155



PART NUMBER 8-NS-23P

WEIGHT WET: 242 LB / 110 KG

WEIGHT DRY: 176 LB / 80 KG

CCA @ 0°F / -17.8 °C 1,520 A

CCA @ 32°F / 0 °C 1,900 A

VOLTAGE: 8 V

OVERALL DIMENSIONS: 28 1/4" X 8 1/4" X 18 1/4"



MAX HEIGHT WITH OPTIONAL HYDROCAPS 18.63" / 473 MM

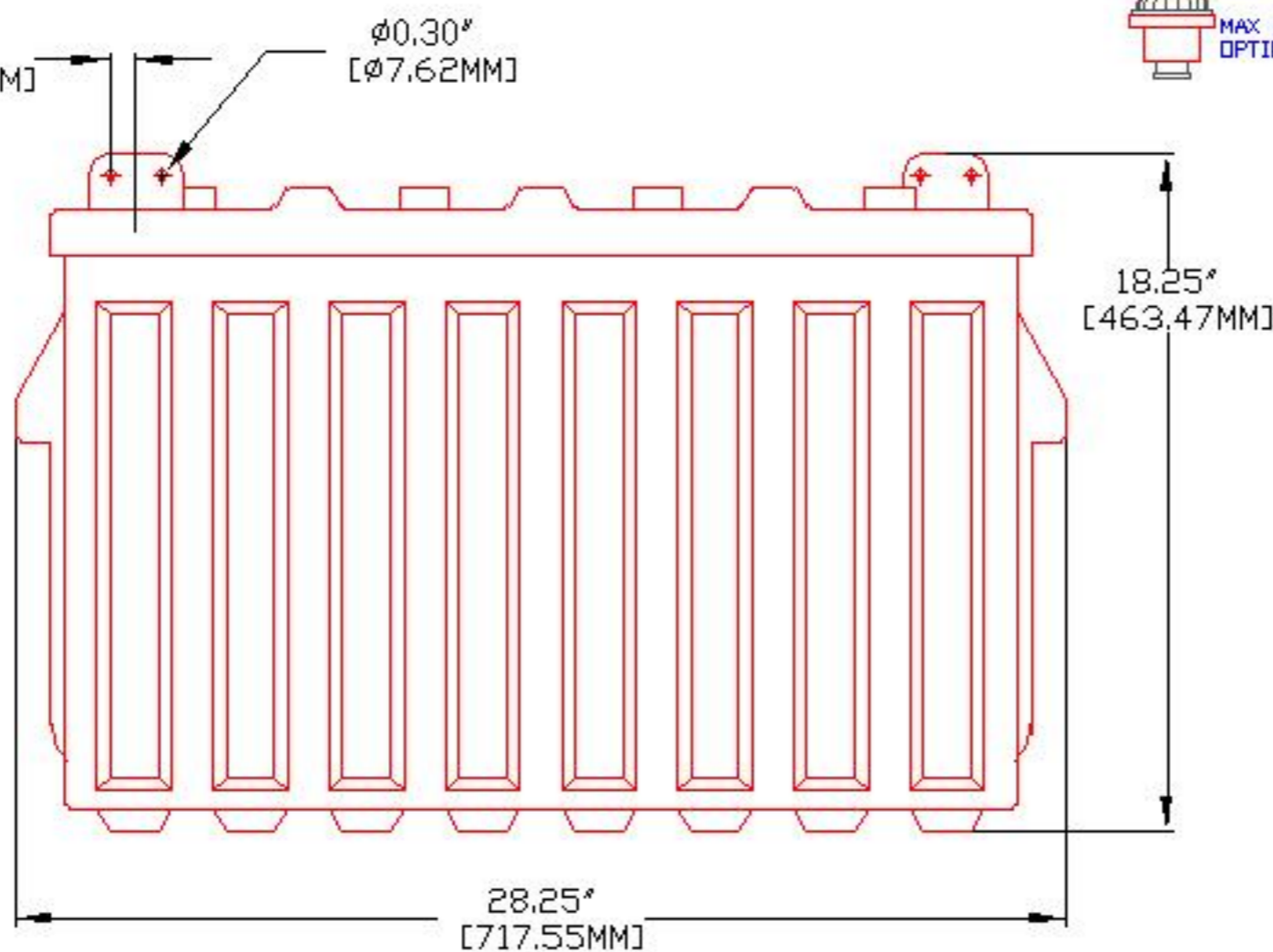
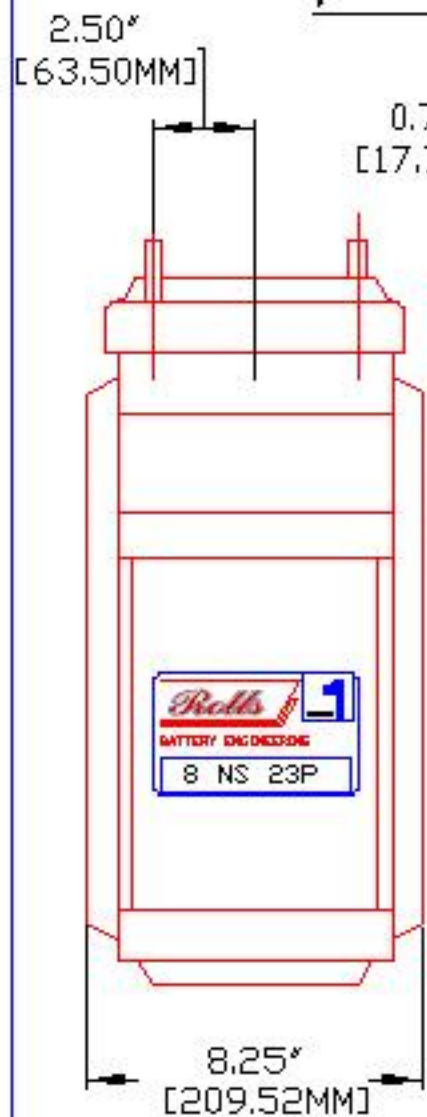

# Rolls

BATTERY ENGINEERING

SALEM, MASS

TITLE:

## 8NS23P

DESCRIPTION:

8V 500/5000 SERIES

CONTACT INFO:

WEB: [WWW.ROLLSBATTERY.COM](http://WWW.ROLLSBATTERY.COM)  
E-MAIL: [SALES@ROLLSBATTERY.COM](mailto:SALES@ROLLSBATTERY.COM)  
PHONE: 1-800-681-9914

SCALE:

1" = 6" 1" = 4" JPEG  
8.5" X 11" 11" X 17" NOT TO SCALE

Drawn by:

S. WILES

Approved By:

D. SURRETTE

DATE:

16-Feb-01

REVISION 2.1

DRAWING NO.:

DWG 013, 8NS23P