

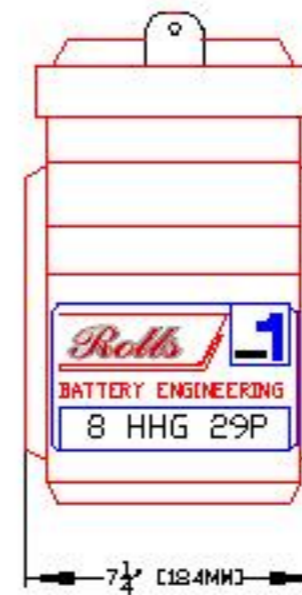

PART NUMBER: 8-HHG-29P
 WEIGHT WET: 150 LB / 68 KG
 WEIGHT DRY: 103 LB / 47 KG
 CAPACITY: 300 AH 20 HR
 CCA @ 0°F / -17.8 °C: 1,350 A
 CCA @ 32°F / 0 °C: 1,688 A
 VOLTAGE: 8 V
 OVERALL DIMENSIONS: 27x 7 1/4x 12"

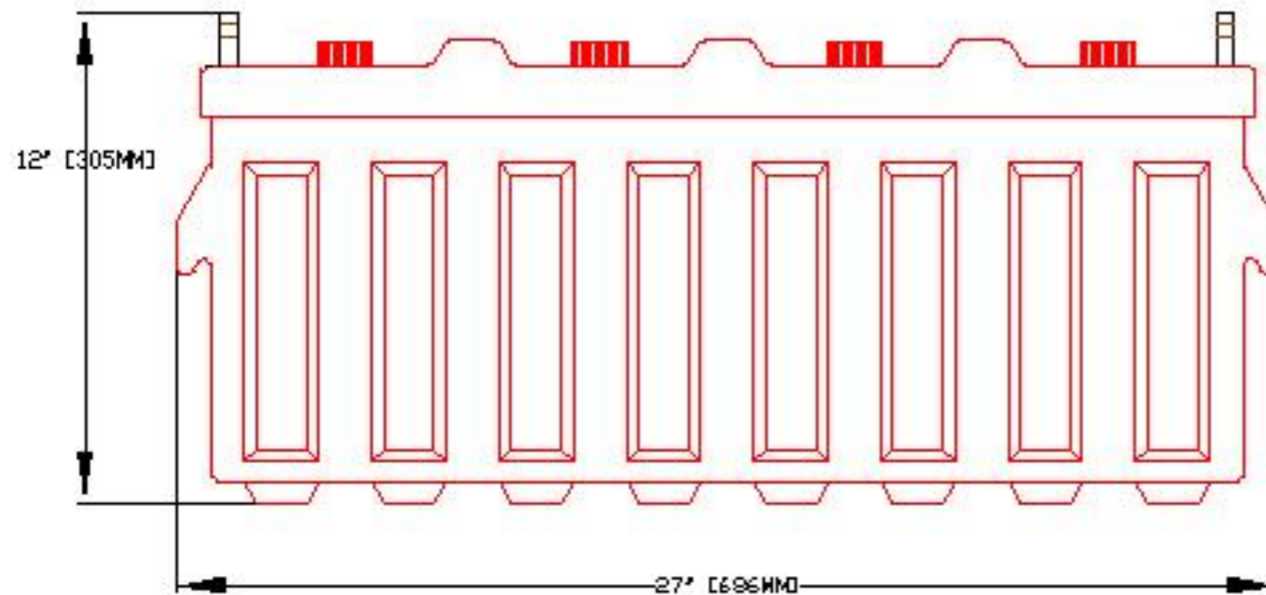

MAX HEIGHT WITH OPTIONAL HYDROCAPS: 12.58" / 320 MM

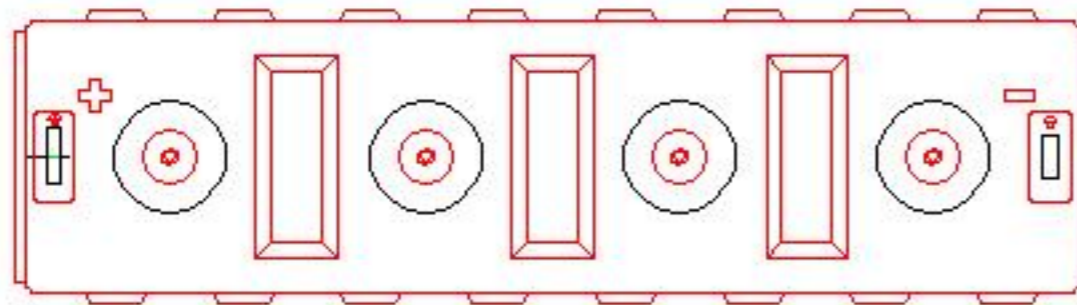

Rolls

BATTERY ENGINEERING SALEM, MASS

TITLE: 8HHG29P

DESCRIPTION: 8V DEEP CYCLE 400/4000 SERIES

CONTACT INFO:

WEB: WWW.ROLLSBATTERY.COM
 E-MAIL: SALES@ROLLSBATTERY.COM
 PHONE: 1-800-681-9914

SCALE: 1" = 6" 1" = 4" JPEG
 8.5" X 11" 11" X 17" NOT TO SCALE

Drawn by: S. WILES Approved By: D. SURRETTE

DATE: 20-Feb-01 REVISION 1.1

DRAWING NO: DWG 025, BD8HHG29P