



# DEEP CYCLE-MARINE SERIES 5000

<b>BATTERY TYPE</b>	<b>VOLTS</b>	<b>8</b>	<b>8 CH 23PM</b>
<b>DIMENSIONS</b>			
LENGTH	718 MM	28 1/4	INCHES
WIDTH	210 MM	8 1/4	INCHES
HEIGHT	464 MM	18 1/4	INCHES
<b>WEIGHT DRY</b>	92 KG	202	LBS.
<b>WEIGHT WET</b>	116 KG	256	LBS.
<b>CONTAINER CONSTRUCTION</b>			
INNER CONTAINER	POLYPROPYLENE		
INNER COVER	POLYPROPYLENE - HEAT SEALED TO INNER CONTAINER		
OUTER CONTAINER	HIGH DENSITY POLYETHYLENE		
OUTER COVER	HIGH DENSITY POLYETHYLENE SNAP FIT TO OUTER CONTAINER		
HANDLES	MOLDED		
<b>PLATES PER CELL</b>	23		
<b>ELECTROLYTE RESERVE</b> ABOVE PLATES	95 MM	3.75	INCHES
<b>DESIGN CRITREA</b> 10 YEAR WARRANTY	1350 CYCLES	15	YEAR LIFE
<b>POSITIVE PLATE DIMENSION</b>			
HEIGHT	270 MM	10.625	INCHES
WIDTH	143 MM	5.625	INCHES
THICKNESS	3.81 MM	0.150	INCHES
<b>NEGATIVE PLATE DIMENSION</b>			
HEIGHT	270 MM	10.625	INCHES
WIDTH	143 MM	5.625	INCHES
THICKNESS	3.05 MM	0.120	INCHES
<b>SEPARATOR INSULATION</b>	SEPARATOR THICKNESS	0.105 INCH	
	0.020" GLASS MAT		
<b>TERMINALS</b>	FLAG WITH STAINLESS STEEL NUTS AND BOLTS		
<b>COLD CRANK</b>	CCA    0°F / -17.8°C	1866	<b>RESERV</b>
	MCA    32°F / 0°C	2333	<b>MINUTES AT 25A</b> 969
<b>CAPACITY</b>	20 HR RATE	582	
			CAP / AH CURRENT / AMPS
<b>CAPACITY AT THE 20 HOUR RATE</b>	<b>1.265 SP. GR.</b>	<b>582</b>	<b>29.1</b>
CAPACITY AT THE 15 HOUR RATE	1.265 SP. GR.	547	36.5
CAPACITY AT THE 12 HOUR RATE	1.265 SP. GR.	518	43.2
CAPACITY AT THE 10 HOUR RATE	1.265 SP. GR.	495	49.5
CAPACITY AT THE 8 HOUR RATE	1.265 SP. GR.	466	58.2
CAPACITY AT THE 6 HOUR RATE	1.265 SP. GR.	431	71.8
CAPACITY AT THE 5 HOUR RATE	1.265 SP. GR.	407	81
CAPACITY AT THE 4 HOUR RATE	1.265 SP. GR.	378	95
CAPACITY AT THE 3 HOUR RATE	1.265 SP. GR.	343	114
CAPACITY AT THE 2 HOUR RATE	1.265 SP. GR.	297	148
CAPACITY AT THE 1 HOUR RATE	1.265 SP. GR.	210	210



PART NUMBER: 8-CH-23P

WEIGHT WET: 256 LB / 116 KG

WEIGHT DRY: 202 LB / 92 KG

CCA @ 0°F / -17.8 °C 1,866 A

CCA @ 32°F / 0 °C 2,333 A

VOLTAGE: 8 V

OVERALL DIMENSIONS 28 1/4" X 8 1/4" X 18 1/4"

MAX HEIGHT WITH OPTIONAL HYDROCAPS 18.63" / 473 MM

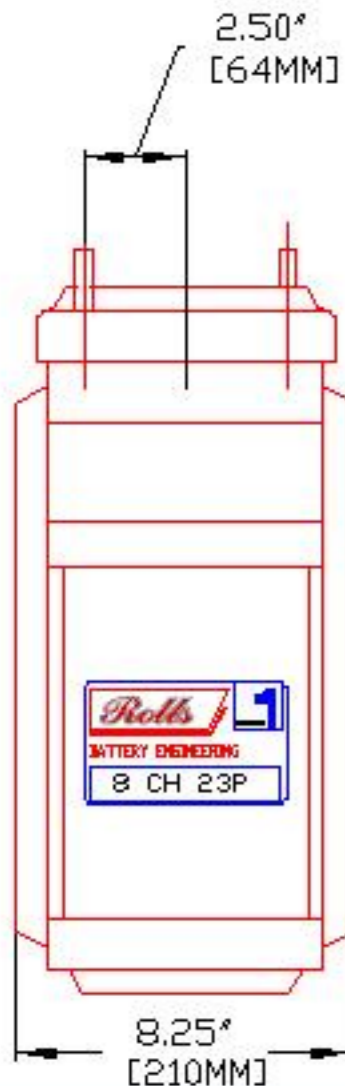
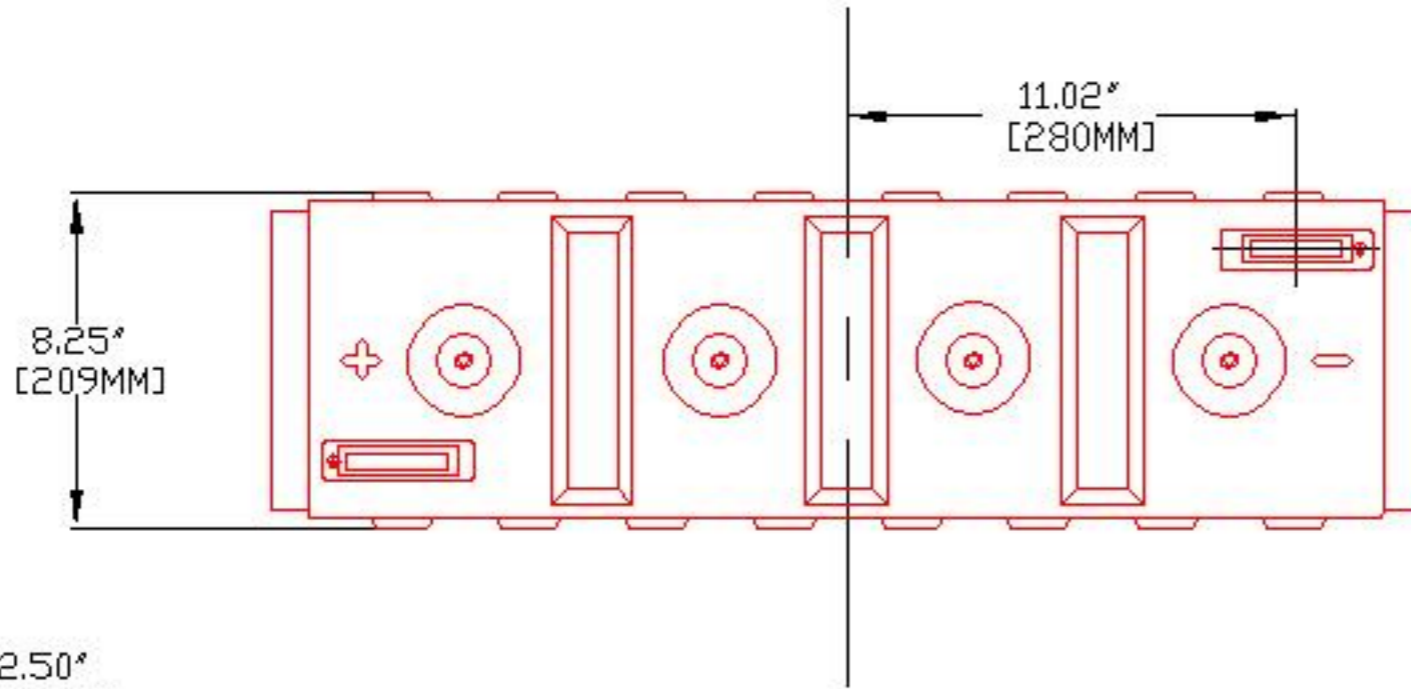

0.70" [18MM] and  $\phi 0.30"$  [ $\phi 8$ MM]

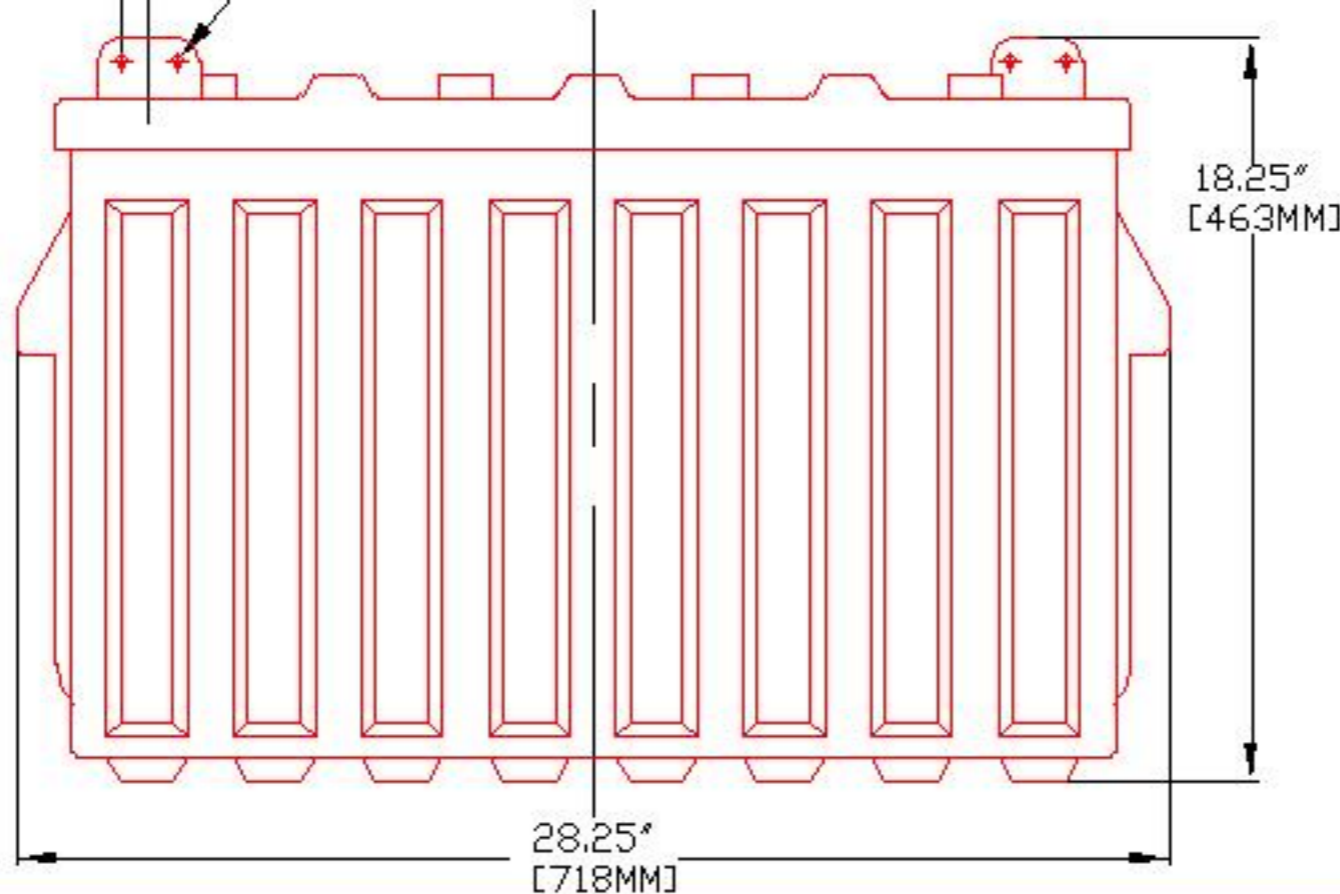

*Rolls*

BATTERY ENGINEERING

SALEM, MASS

TITLE

8CH23P

DESCRIPTION

8V 500/5000 SERIES

CONTACT INFO:

WEB: WWW.ROLLSBATTERY.COM  
E-MAIL: SALES@ROLLSBATTERY.COM  
PHONE: 1-800-681-9914

SCALE 1" = 6" 1" = 4" JPEG  
8.5" X 11" 11" X 17" NOT TO SCALE

Drawn By

S. WILES

Approved By

D. SURRETTE

DATE

16-Feb-01

REVISION

2.1

DRAWING NO:

DWG 013, BD8CH23P