



# DEEP CYCLE-MARINE SERIES 5000

<b>BATTERY TYPE</b>	<b>VOLTS</b>	<b>6</b>	<b>6 CS 17PM</b>	
<b>DIMENSIONS</b>				
LENGTH		559 MM	22	INCHES
WIDTH		210 MM	8 1/4	INCHES
HEIGHT		464 MM	18 1/4	INCHES
<b>WEIGHT DRY</b>		81 KG	178	LBS.
<b>WEIGHT WET</b>		100 KG	221	LBS.
<b>CONTAINER CONSTRUCTION</b>				
INNER CONTAINER		POLYPROPYLENE		
INNER COVER		POLYPROPYLENE - HEAT SEALED TO INNER CONTAINER		
OUTER CONTAINER		HIGH DENSITY POLYETHYLENE		
OUTER COVER		HIGH DENSITY POLYETHYLENE SNAP FIT TO OUTER CONTAINER		
HANDLES		MOLDED		
<b>PLATES PER CELL</b>		17		
<b>ELECTROLYTE RESERVE</b>	ABOVE PLATES	95 MM	3.75	INCHES
<b>DESIGN CRITREA</b>	10 YEAR WARRANTY	3300	CYCLES	15 YEAR LIFE
<b>POSITIVE PLATE DIMENSION</b>				
HEIGHT		273 MM	10.750	INCHES
WIDTH		143 MM	5.625	INCHES
THICKNESS		6.73 MM	0.265	INCHES
<b>NEGATIVE PLATE DIMENSION</b>				
HEIGHT		273 MM	10.750	INCHES
WIDTH		143 MM	5.625	INCHES
THICKNESS		4.70 MM	0.185	INCHES
<b>SEPARATOR</b>	SEPARATOR THICKNESS	0.105 INCH		
<b>INSULATION</b>	POSITVE PLATE ENVELOPED BY VERTICAL SLYVER GLASS MAT			
<b>TERMINALS</b>	FLAG WITH STAINLESS STEEL NUTS AND BOLTS			
<b>COLD CRANK</b>	CCA	0°F / -17.8°C	1357	<b>RESERVE</b>
	MCA	32°F / 0°C	1696	<b>MINUTES AT 25A</b>
				1083
<b>CAPACITY</b>	20 HR RATE	546		
		CAP / AH	CURRENT / AMPS	
<b>CAPACITY AT THE 20 HOUR RATE</b>	<b>1.265 SP. GR.</b>	<b>546</b>	<b>27.3</b>	
CAPACITY AT THE 15 HOUR RATE	1.265 SP. GR.	513	34.2	
CAPACITY AT THE 12 HOUR RATE	1.265 SP. GR.	486	40.5	
CAPACITY AT THE 10 HOUR RATE	1.265 SP. GR.	464	46.4	
CAPACITY AT THE 8 HOUR RATE	1.265 SP. GR.	437	54.6	
CAPACITY AT THE 6 HOUR RATE	1.265 SP. GR.	404	67.3	
CAPACITY AT THE 5 HOUR RATE	1.265 SP. GR.	382	76	
CAPACITY AT THE 4 HOUR RATE	1.265 SP. GR.	355	89	
CAPACITY AT THE 3 HOUR RATE	1.265 SP. GR.	322	107	
CAPACITY AT THE 2 HOUR RATE	1.265 SP. GR.	278	139	
CAPACITY AT THE 1 HOUR RATE	1.265 SP. GR.	197	197	



PART NUMBER: 6-CS-17P  
 WEIGHT WET: 221 LB / 100 KG  
 WEIGHT DRY: 178 LB / 81 KG  
 CAPACITY: 546 AH 20 HR  
 770 AH 100 HR  
 VOLTAGE: 6 V  
 OVERALL DIMENSIONS: 22X8 1/4X18 1/4"  
 MAX HEIGHT WITH OPTIONAL HYDROCAPS: 18 5/8" - 473 MM

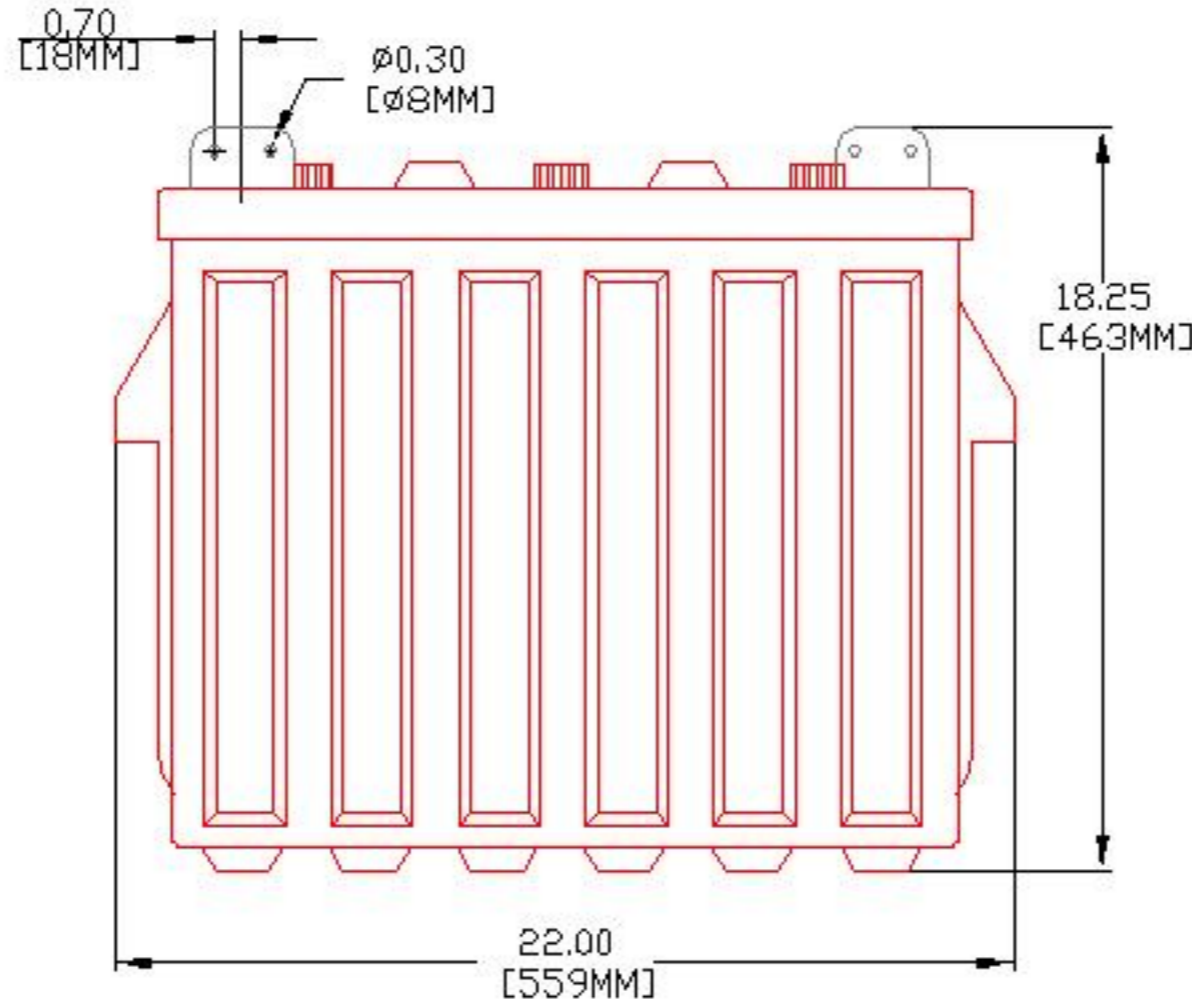
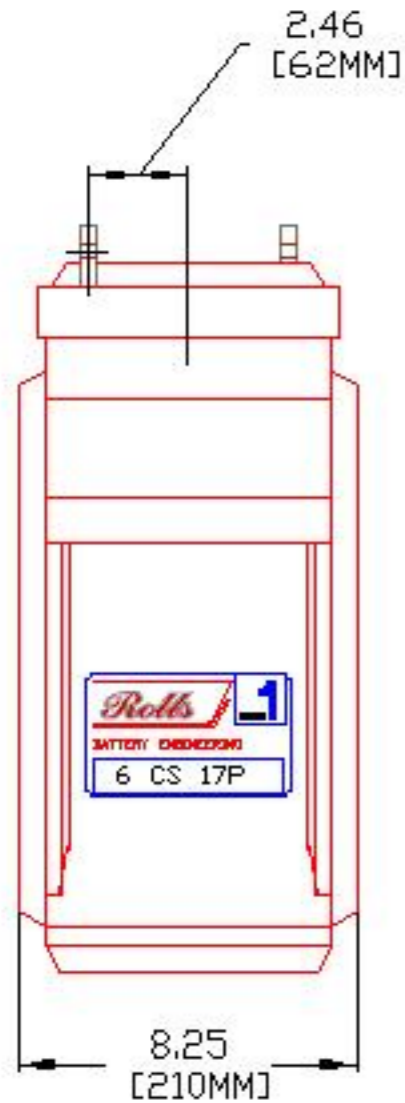
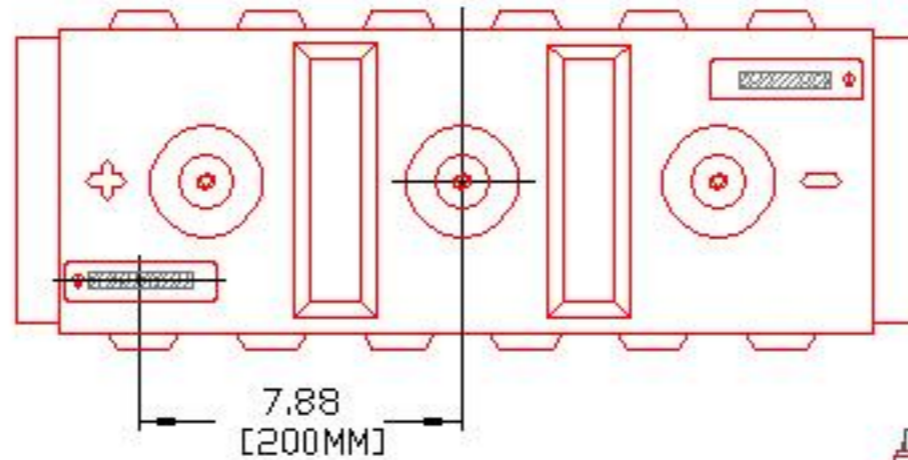

*Rolls*

BATTERY ENGINEERING SALEM, MASS

TITLE: 6CS17P

DESCRIPTION: 6V / 3 CELL 17 PLATE (CS) DEEP CYCLE 500/5000 SERIES

CONTACT INFO: WEB: WWW.ROLLSBATTERY.COM  
 E-MAIL: SALES@ROLLSBATTERY.COM  
 PHONE: 1-800-681-9914

SCALE: 1" = 6" 1" = 4" JFEG  
 8.5" X 11" 11" X 17" NOT TO SCALE

Drawn by: S. WILES Approved By: D. SURRETTE

DATE: 14-JUN-00 REVISION 2.1

DRAWING NO.: DWG 005, BD6CS17P