



# DEEP CYCLE-MARINE SERIES 5000

**BATTERY TYPE** VOLTS 2 **2 KS 33PM**

**DIMENSIONS**

LENGTH	392 MM	15 4/9	INCHES
WIDTH	211 MM	8 1/3	INCHES
HEIGHT	630 MM	24 4/5	INCHES

WEIGHT DRY	66 KG	145	LBS.
WEIGHT WET	95 KG	208	LBS.

**CONTAINER CONSTRUCTION**

INNER CONTAINER	POLYPROPYLENE
INNER COVER	POLYPROPYLENE - HEAT SEALED TO INNER CONTAINER
OUTER CONTAINER	HIGH DENSITY POLYETHYLENE
OUTER COVER	HIGH DENSITY POLYETHYLENE SNAP FIT TO OUTER CONTAINER
HANDLES	MOLDED

**PLATES PER CELL** 33

**ELECTROLYTE RESERVE** ABOVE PLATES 95 MM 3.75 INCHES

**DESIGN CRITREA** 10 YEAR WARRANTY 3300 CYCLES 15 YEAR LIFE

**POSITIVE PLATE DIMENSION**

HEIGHT	432 MM	17.0	INCHES
WIDTH	143 MM	5.625	INCHES
THICKNESS	6.99 MM	0.275	INCHES

**NEGATIVE PLATE DIMENSION**

HEIGHT	432 MM	17.0	INCHES
WIDTH	143 MM	5.625	INCHES
THICKNESS	4.57 MM	0.180	INCHES

**SEPARATOR INSULATION** SEPARATOR THICKNESS 0.105 INCH  
 POSITIVE PLATE DOUBLE WRAPPED WITH SLYVER 0.020 HEAVY GLASS MAT AND ENVELOPED WITH HEAVY DUTY SEPARATOR

**TERMINALS** FLAG WITH STAINLESS STEEL NUTS AND BOLTS

<b>COLD CRANK</b>	CCA	0°F / -17.8°C	4952	<b>RESERVE</b>	
	MCA	32°F / 0°C	6190	<b>MINUTES AT 25A</b>	4915

**CAPACITY** 20 HR RATE 1766

		CAP / AH	CURRENT / AMPS
<b>CAPACITY AT THE 20 HOUR RATE</b>	<b>1.265 SP. GR.</b>	<b>1766</b>	<b>88.3</b>
CAPACITY AT THE 15 HOUR RATE	1.265 SP. GR.	1660	110.7
CAPACITY AT THE 12 HOUR RATE	1.265 SP. GR.	1572	131.0
CAPACITY AT THE 10 HOUR RATE	1.265 SP. GR.	1501	150.1
CAPACITY AT THE 8 HOUR RATE	1.265 SP. GR.	1413	176.6
CAPACITY AT THE 6 HOUR RATE	1.265 SP. GR.	1307	217.8
CAPACITY AT THE 5 HOUR RATE	1.265 SP. GR.	1236	247
CAPACITY AT THE 4 HOUR RATE	1.265 SP. GR.	1148	287
CAPACITY AT THE 3 HOUR RATE	1.265 SP. GR.	1042	347
CAPACITY AT THE 2 HOUR RATE	1.265 SP. GR.	901	450
CAPACITY AT THE 1 HOUR RATE	1.265 SP. GR.	636	636

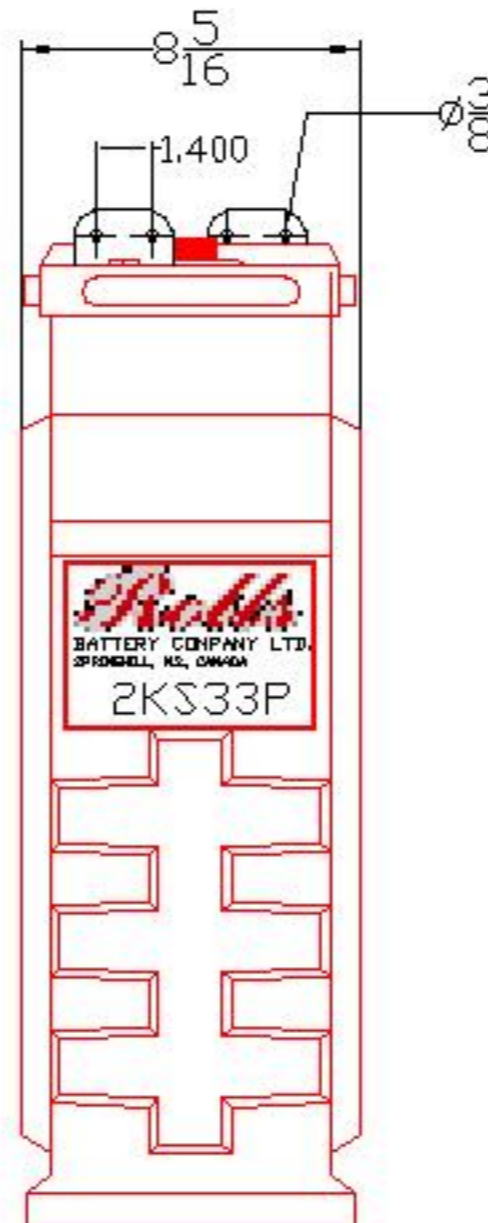
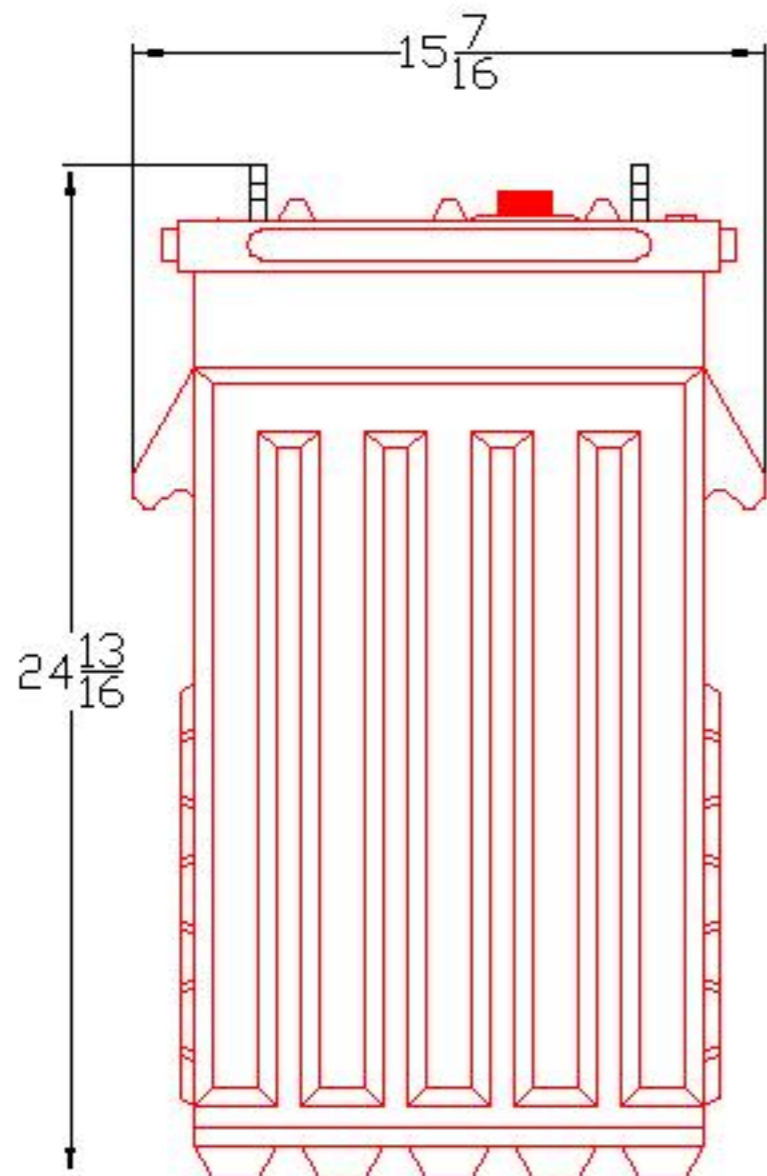
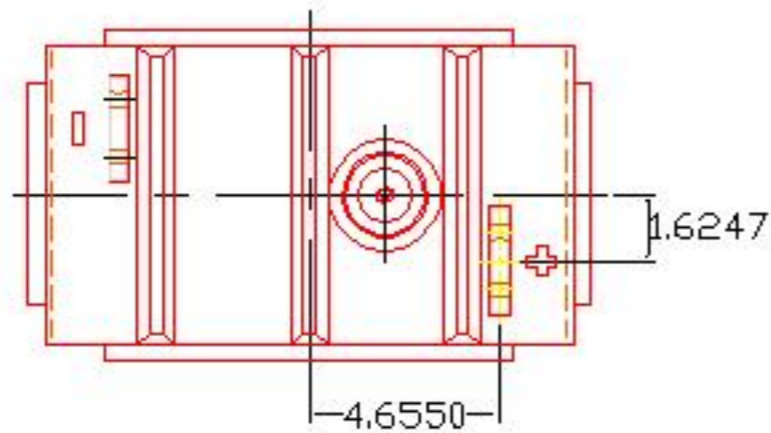

PART NUMBER: 2-KS-33P  
 WEIGHT WET: 208 LB/ 94 KG  
 WEIGHT DRY: 145 LB/ 66 KG  
 CAPACITY: 1,448 AH 8 HR  
 1,766 AH 20 HR  
 2,491 AH 100 HR

OVERALL DIMS: 15<sup>7</sup>/<sub>16</sub> X 8<sup>5</sup>/<sub>16</sub> X 24<sup>13</sup>/<sub>16</sub>



MAX HT WITH OPTIONAL 25<sup>1</sup>/<sub>2</sub> " HYDROCAPS



BATTERY ENGINEERING  
 SALEM, MASS. PRODUCT OF CANADA

TITLE: 2 KS 33P

DESCRIPTION:  
 2V / 1 CELL 33 PLATE 500/5000 SERIES

CONTACT INFO:  
 WEB: WWW.ROLLSBATTERY.COM  
 E-MAIL: SALES@ROLLSBATTERY.COM  
 PHONE: 1-800-681-9914

SCALE: 1" = 6"      JPEG:  
 8.5" X 11"      NOT TO SCALE

DATE: 20-APR-04      REVISION REV 1

DRAWING NO: DWG 066, BD2KS33P