

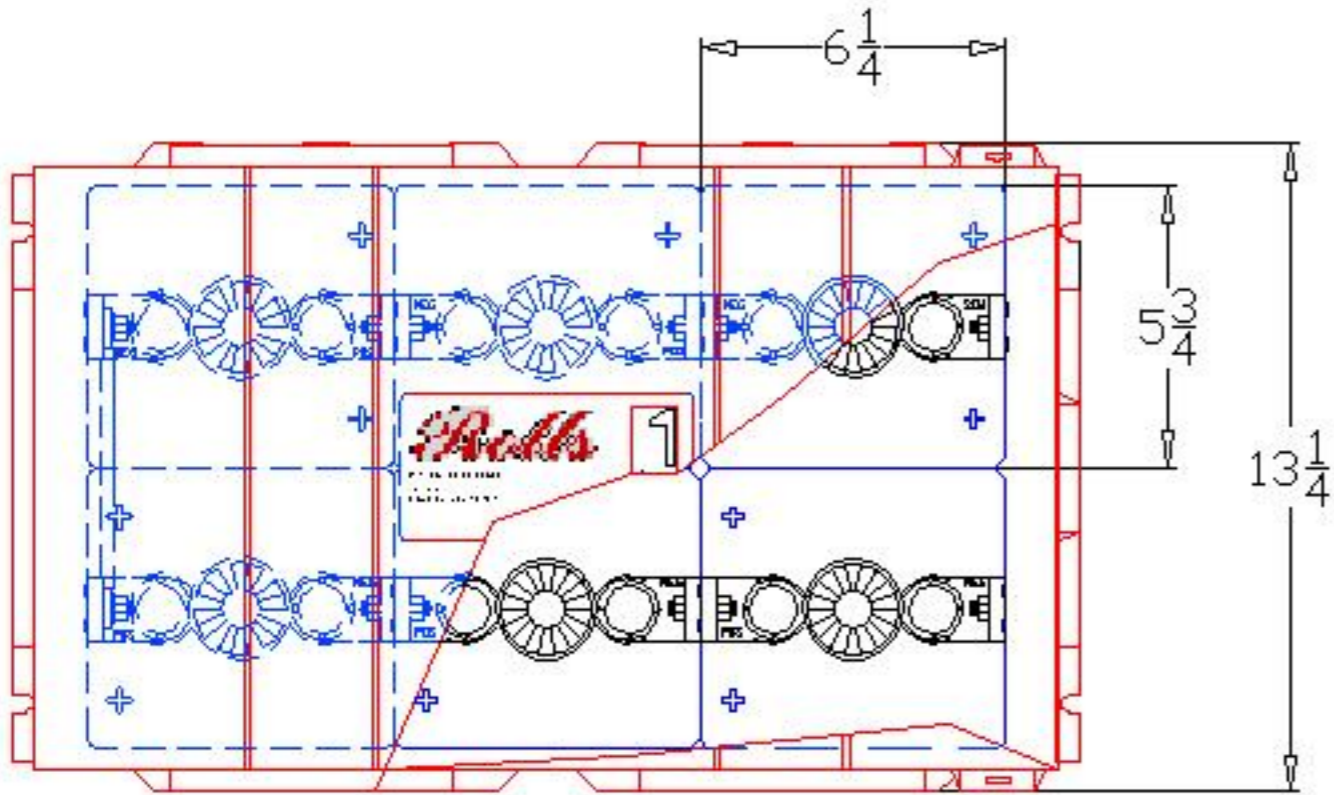

# DEEP CYCLE-MARINE SERIES 4000

<b>BATTERY TYPE</b>	<b>VOLTS</b>	<b>12</b>	<b>12 HHG 325PM</b>
<b>DIMENSIONS</b>			
LENGTH		552 MM	21 3/4 INCHES
WIDTH		337 MM	13 1/4 INCHES
HEIGHT		287 MM	11 5/16 INCHES
<b>WEIGHT DRY</b>		68 KG	150 LBS.
<b>WEIGHT WET</b>		91 KG	200 LBS.
<b>CONTAINER CONSTRUCTION</b>			
CONTAINER		POLYPROPYLENE	
COVER		POLYPROPYLENE	
HANDLES		MOLDED	
SPECIAL		6 REMOVALABLE BOLT-TOGETHER CELLS IN 8D BATTERY BOX	
<b>PLATES PER CELL</b>		25	
<b>ELECTROLYTE RESERVE</b>	ABOVE PLATES	57 MM	2.25 INCHES
<b>DESIGN CRITREA</b>	7 YEAR WARRANTY	1300CYCLES	10 YEAR LIFE
<b>POSITIVE PLATE DIMENSION</b>			
HEIGHT		140 MM	5 1/2 INCHES
WIDTH		143 MM	5.625 INCHES
THICKNESS		3.18 MM	0.125 INCHES
<b>NEGATIVE PLATE DIMENSION</b>			
HEIGHT		140 MM	5 1/2 INCHES
WIDTH		143 MM	5.625 INCHES
THICKNESS		2.08 MM	0.082 INCHES
<b>SEPARATOR INSULATION</b>	SEPARATOR THICKNESS	0.061 INCH	
	0.020" GLASS MAT		
<b>TERMINALS</b>	BOLT ON - STANDARD		
<b>COLD CRANK</b>	CCA	0°F / -17.8°C	1350
	MCA	32°F / 0°C	1688
		<b>RESERV</b>	650
		<b>MINUTES AT 25A</b>	
<b>CAPACITY</b>	20 HR RATE	325	
		CAP / AH    CURRENT / AMPS	
<b>CAPACITY AT THE 20 HOUR RATE</b>	<b>1.265 SP. GR.</b>	<b>325</b>	<b>16.3</b>
CAPACITY AT THE 15 HOUR RATE	1.265 SP. GR.	306	20.4
CAPACITY AT THE 12 HOUR RATE	1.265 SP. GR.	289	24.1
CAPACITY AT THE 10 HOUR RATE	1.265 SP. GR.	276	27.6
CAPACITY AT THE 8 HOUR RATE	1.265 SP. GR.	260	32.5
CAPACITY AT THE 6 HOUR RATE	1.265 SP. GR.	241	40.1
CAPACITY AT THE 5 HOUR RATE	1.265 SP. GR.	228	46
CAPACITY AT THE 4 HOUR RATE	1.265 SP. GR.	211	53
CAPACITY AT THE 3 HOUR RATE	1.265 SP. GR.	192	64
CAPACITY AT THE 2 HOUR RATE	1.265 SP. GR.	166	83
CAPACITY AT THE 1 HOUR RATE	1.265 SP. GR.	117	117

LOW MAINTENANCE  
ONE YEAR WATERING CYCLE



PART NUMBER:	12HHG325
WT WET:	200 LB / 91 KG
WT DRY:	150 LB / 68 KG
INDIVIDUAL CELL WT:	30 LB / 13.6 KG
CC/32°F, 0°C	1,688 A
CCA/ 0°F, -18°C	1,350 A
CAPACITY	325 AH 20 HR
RES (MIN@25AMP)	650
VOLTAGE:	12 V
OVERALL DIM:	$21\frac{3}{4}$ X $13\frac{1}{4}$ X $11\frac{5}{16}$
SINGLE CELL DIM:	$6\frac{1}{4}$ X $5\frac{3}{4}$ X $10\frac{5}{8}$
STANDARD:	HYDROCAPS & BOLT-ON CONNECTORS

COAST GUARD APPROVED CONTAINER  
WHEN CORRECTLY INSTALLED

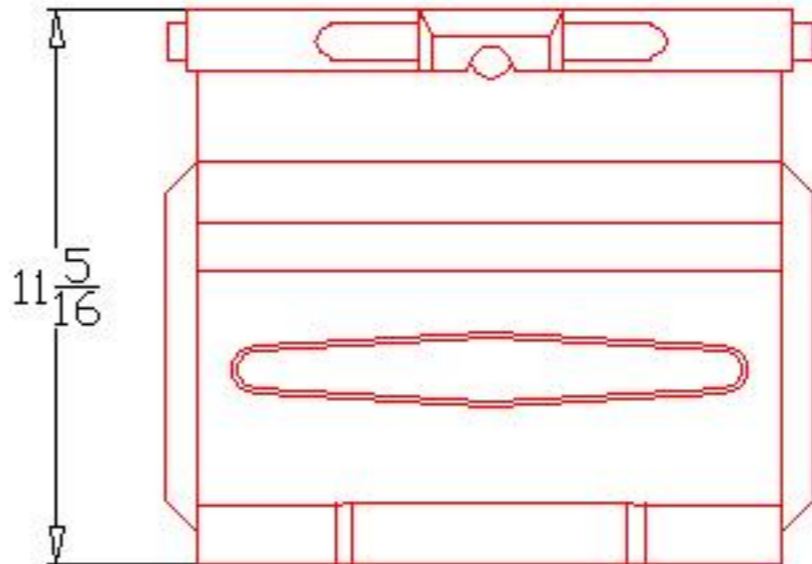
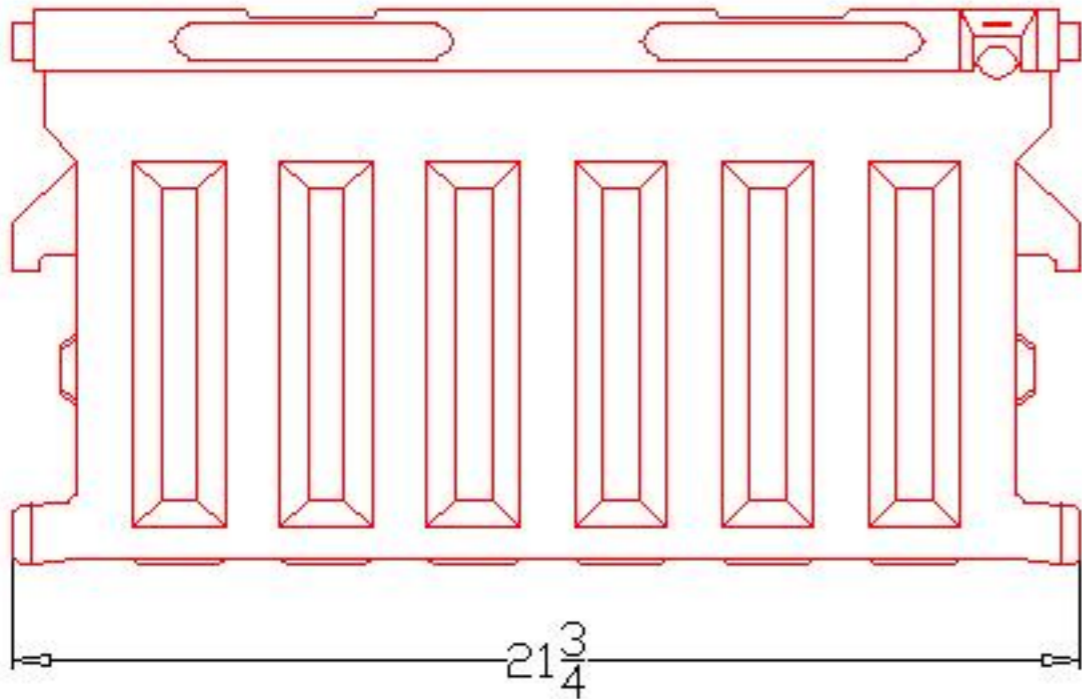

SALEM, MASS, USA

TITLE:  
12HHG325

DESCRIPTION:  
12V DEEP CYCLE SERIES 400/4000

CONTACT INFO:  
WEB: WWW.ROLLSBATTERY.COM  
E-MAIL: SALES@ROLLSBATTERY.COM  
PHONE: 1-800-681-9914

SCALE: 1" = 5" JPEG:  
6.5" X 11" NOT TO SCALE

DATE: OCT-03 REVISION REV. 0

DRAWING NO:  
DWG059, BD-12HHG325P