

MOTORCYCLE LEAD-ACID BATTERY

CTX20HL-BS

12V 18Ah

TYPE		CTX20HL-BS	
NOMINAL VOLTAGE		12V	
NOMINAL CAPACITY		18AH/10HR	
DIMENSIONS			
LENGTH	175.0 mm	TOTAL LENGTH	175.0 mm
WIDTH	87.0 mm	TOTAL WIDTH	87.0 mm
HEIGHT	153.5 mm	TOTAL HEIGHT	153.5 mm
WEIGHT		APPROX. 5.1 KGS	

Dimension

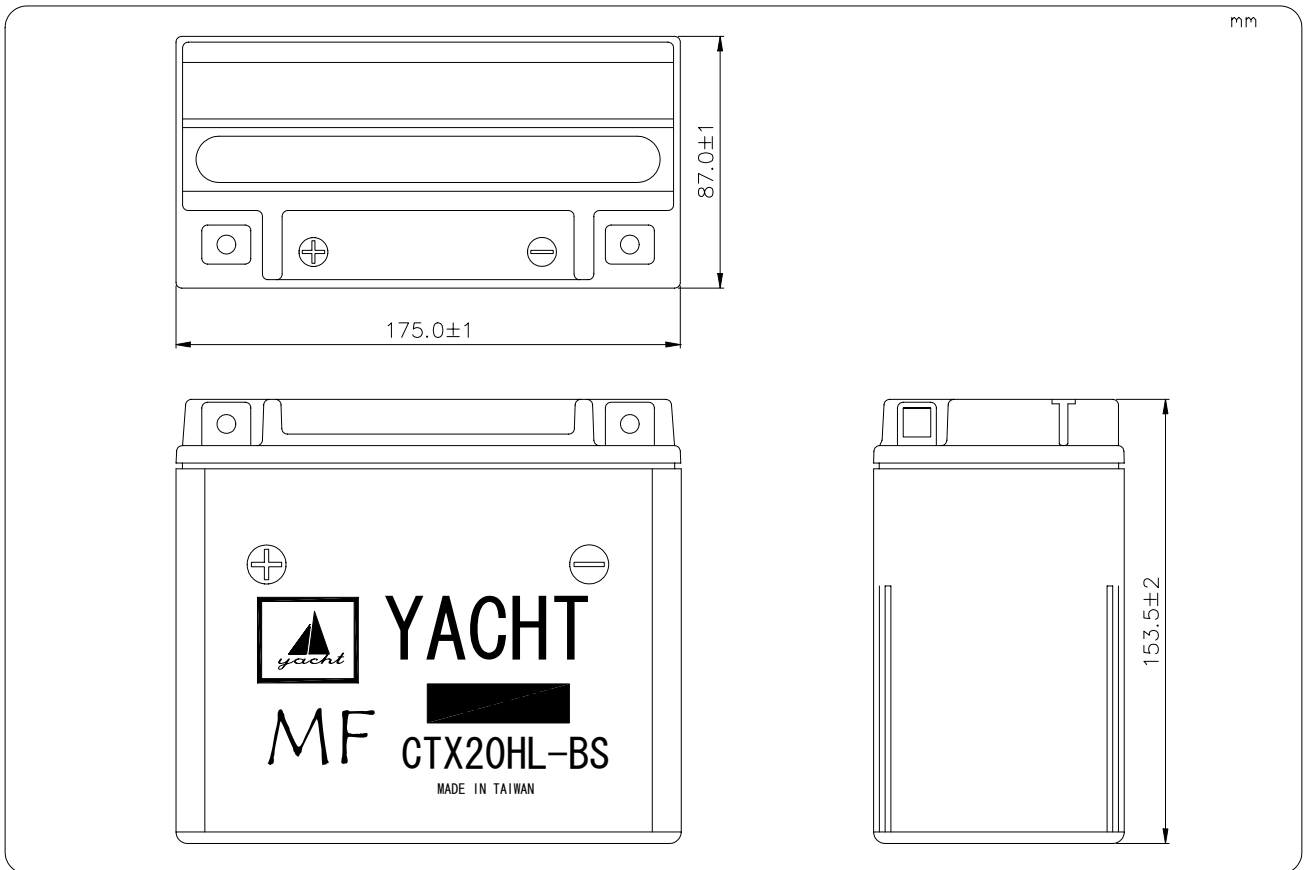

Terminal

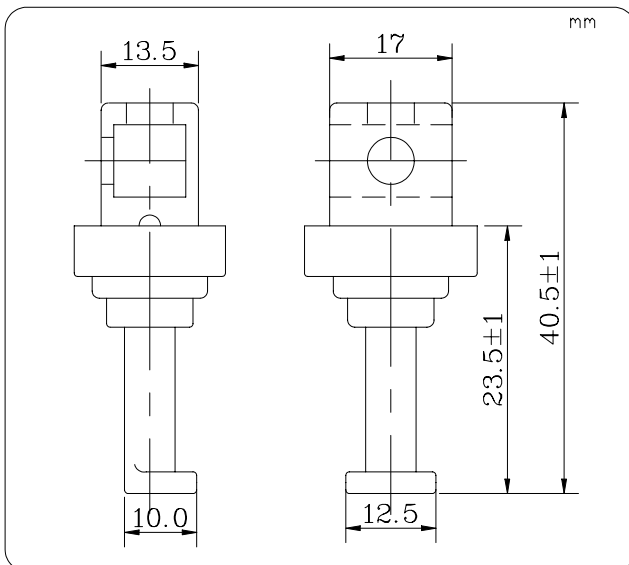

Screw

