



POWERSPORT BATTERY Maintenance-Free AGM Battery Series

CTX14L-BS 12V 12AH(10HR)



JIS JIS
D5302 C8702

Specification

BATTERY TYPE NUMBER	VOLTAGE (V)	CAPACITY AH (10HR)	MAXIMUM DIMENSIONS						WEIGHT			
			MILLIMETERS (±2 mm)			INCHES (±1/16 in)			BATTERY ONLY		INCLUDE ACID AND PACKAGE	
			L	W	H	L	W	H	Kg	Lbs	Kg	Lbs
CTX14L-BS	12	12	150	87	146	5 7/8	3 7/16	5 3/4	3.70	8.15	4.87	10.73

Dimension

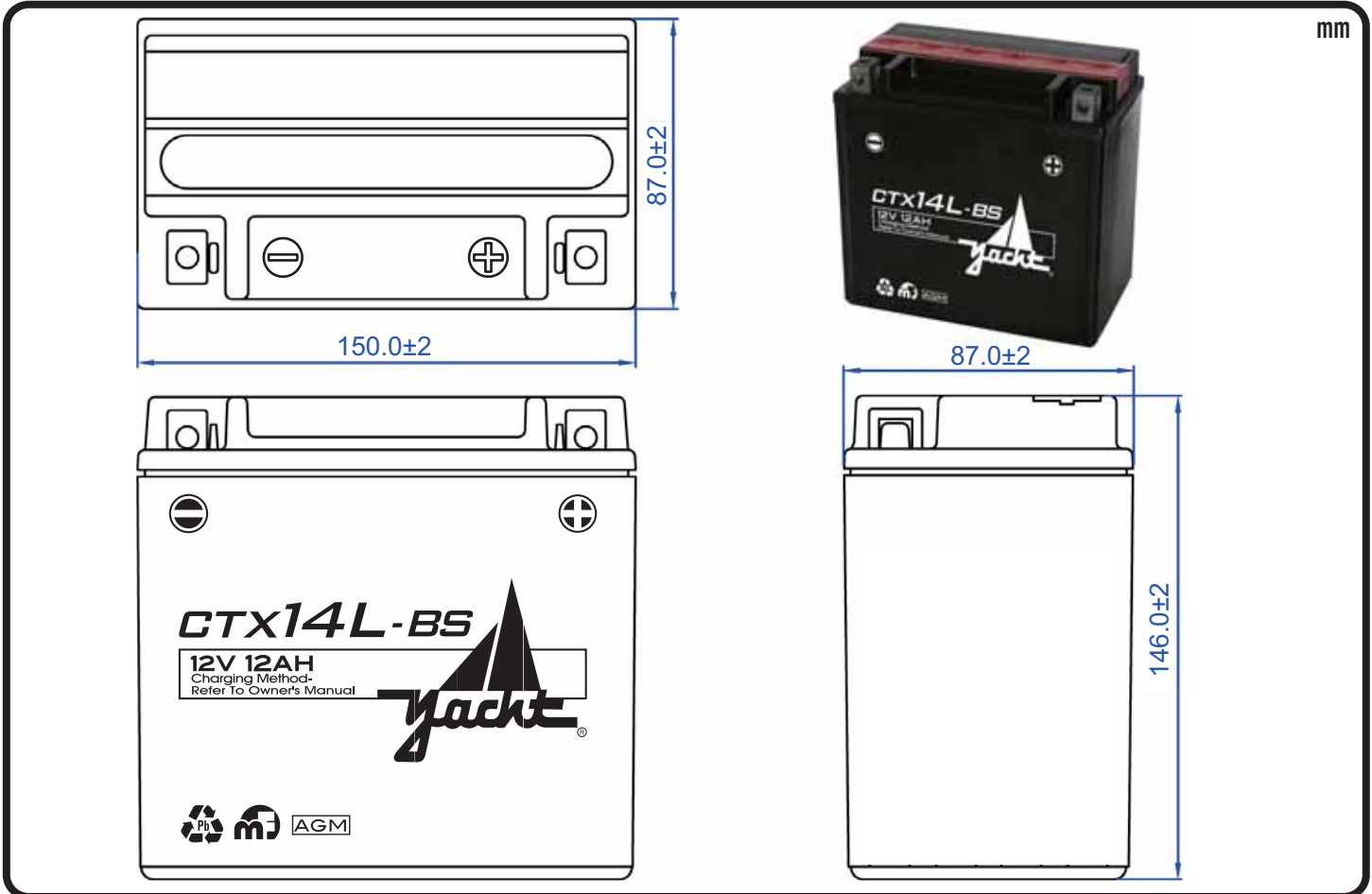

Terminal Configuration

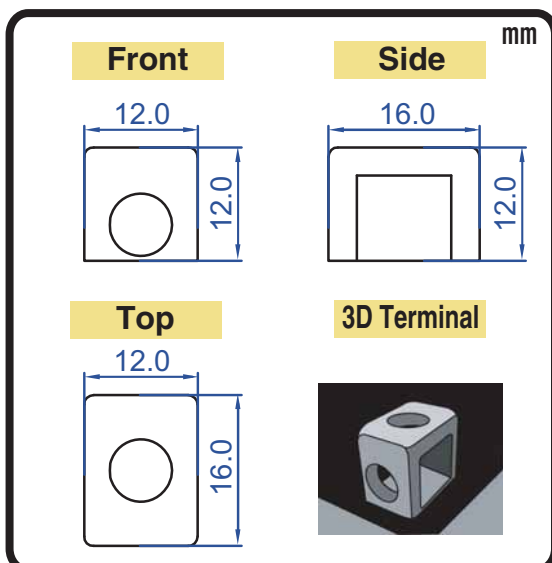

Nut & Bolt Hardware Kits

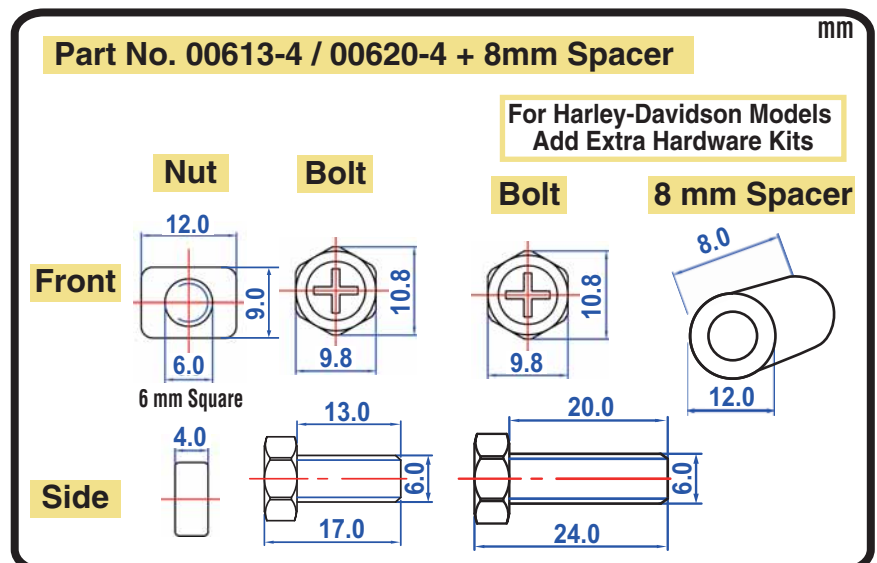

International Sales Division
4F-5, No. 123, Sec. 3, Taichung Port Road,
Taichung, 40767 Taiwan, R.O.C.
Tel : 886-4-2358-0578
Fax : 886-4-2358-0059
E-mail : sales@yacht-battery.com

Alpharetta Office
#429, 12460 Crabapple Road, Suite 202,
Alpharetta, GA 30004, U.S.A.
Tel : 1-678-580-0504
Fax : 1-888-456-5695
E-mail : Chuck.Fowler@yacht-battery.com

Pennsylvania Office
93 S. Sunrise Lane, Boyertown,
PA 19512, U.S.A.
Tel : 1-610-689-0443
Fax : 1-888-373-6466
E-mail : Dave.Beidler@yacht-battery.com